

NOTES:
 1. DIMS IN INCHES
 2. QTY: 1

TITLE:				Design Assembly		
DRAWN						
DESIGNED						
SIZE	DWG. NO.			REV		
A	EML2322L-A-000			A		
SCALE: 1:4				SHEET 1 OF 7		

DIMENSION TYPE	PLACES IN DIMENSION		
	0.0	0.00	0.000
LOCATIONAL	±0.050	±0.020	±0.005
ANGULAR	±5	±2	±0.5

5



4

3

2

1

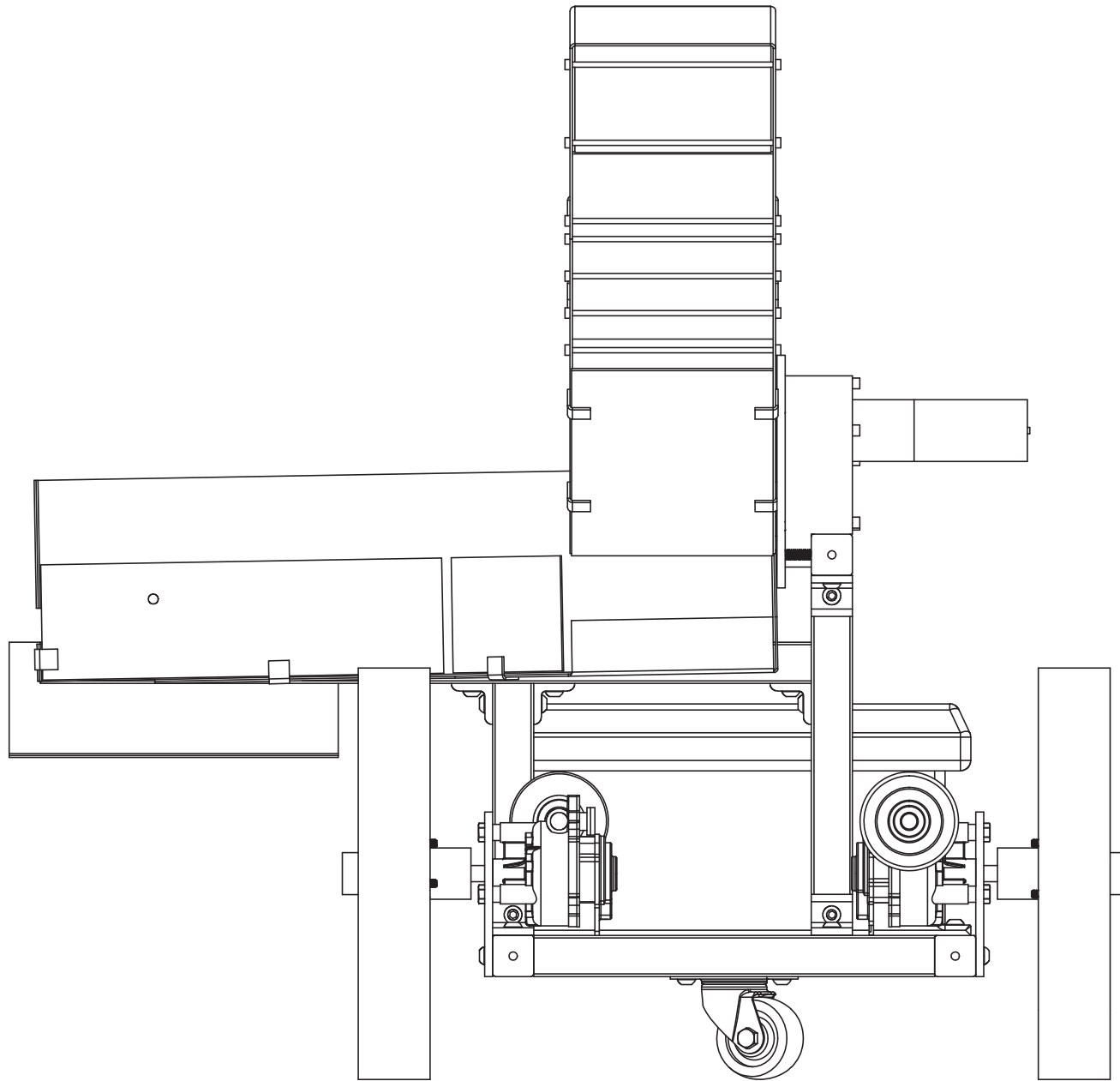

NOTES:
 1. DIMS IN INCHES
 2. QTY: 1

TITLE:				Design Assembly		
DRAWN				[Redacted]		
DESIGNED				[Redacted]		
SIZE	DWG. NO.				REV	
A	EML2322L-A-000				A	
SCALE: 1:4				SHEET 3 OF 7		

DIMENSION TYPE	PLACES IN DIMENSION		
	0.0	0.00	0.000
LOCATIONAL	±0.050	±0.020	±0.005
ANGULAR	±5	±2	±0.5

5



4

3

2

1

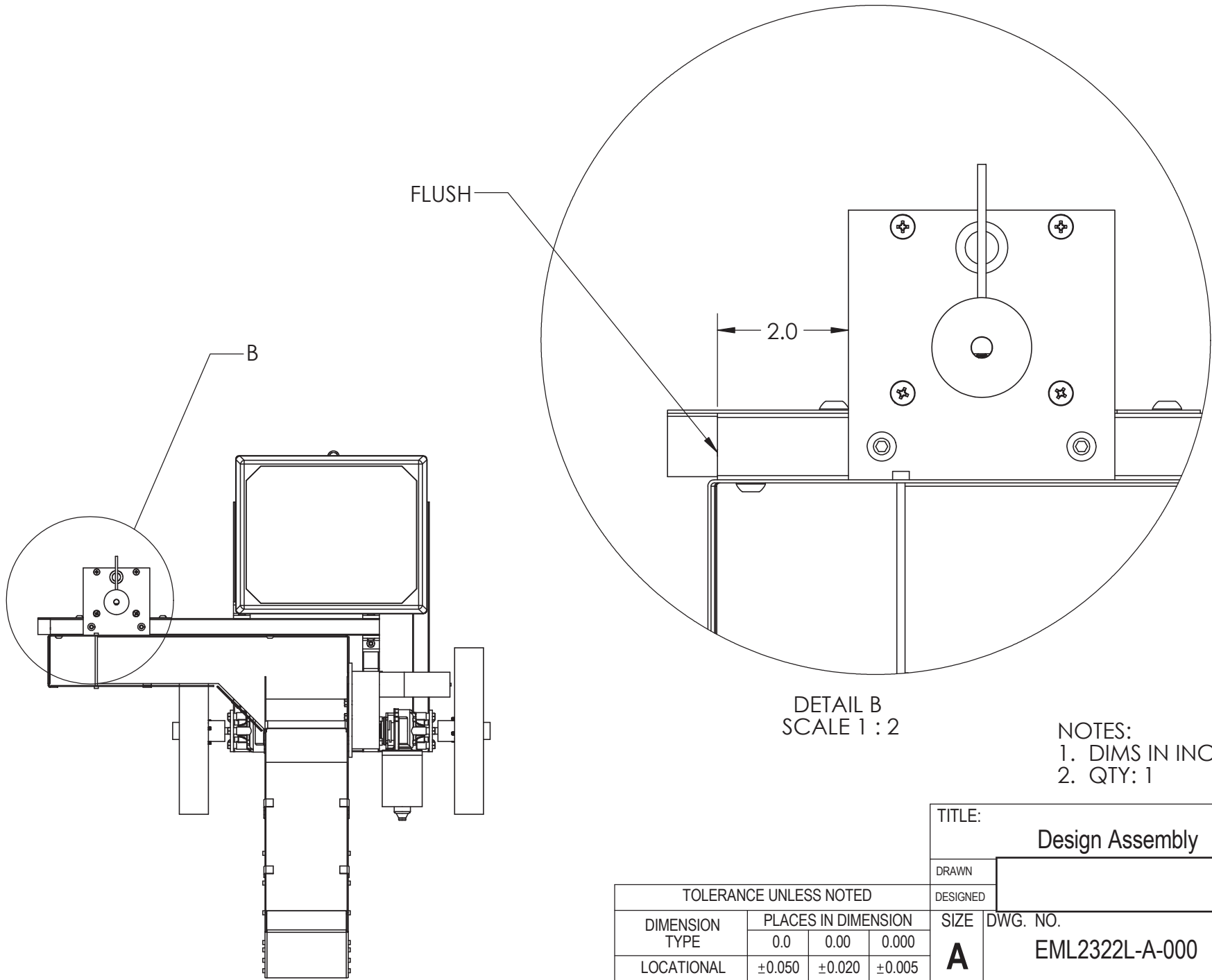

FLUSH

B

DETAIL B
SCALE 1 : 2

- NOTES:
 1. DIMS IN INCHES
 2. QTY: 1

TITLE:				Design Assembly		
DRAWN						
DESIGNED						
DIMENSION TYPE		PLACES IN DIMENSION		SIZE	DWG. NO.	REV
		0.0	0.00	0.000	EML2322L-A-000	A
LOCATIONAL		±0.050	±0.020	±0.005		
ANGULAR		±5	±2	±0.5		
SCALE: 1:8				SHEET 4 OF 7		

5

↑

4

3

2

1

ITEM NO.	PART NUMBER	DESCRIPTION	QTY.
A1	EML2322L-A-100	Mobile Platform	1
A4	EML2322L-A-200	Ball Collector	1
A5	EML2322L-A-300	Hopper	1
A6	EML2322L-A-400	Ball Dispenser	1
28	EML2322L- 501	0.25-20 1" countersunk phillips screw	2
29	EML2322L-502	0.25-20 Button Head Cap Screw	4
32	EML2322L-505	80/20 0.25-20 T-NUT	6

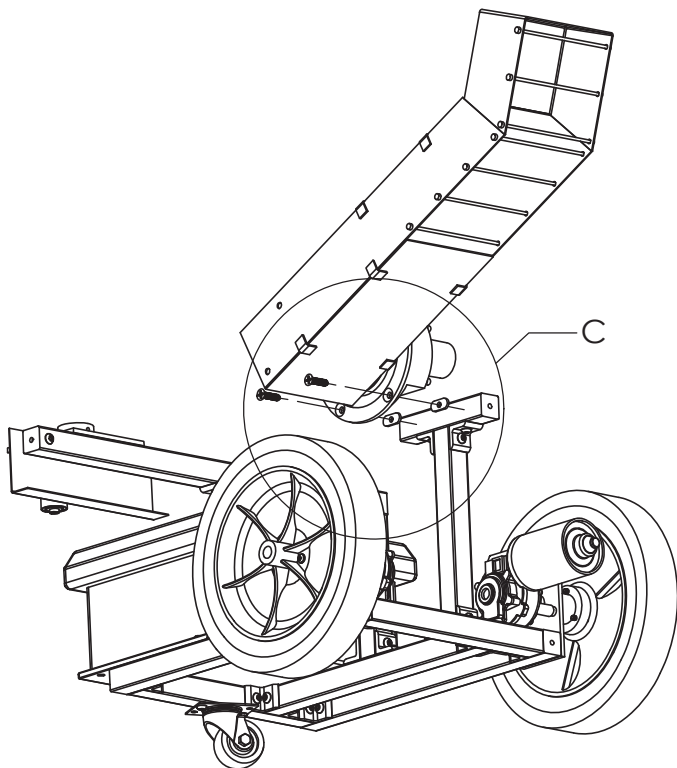
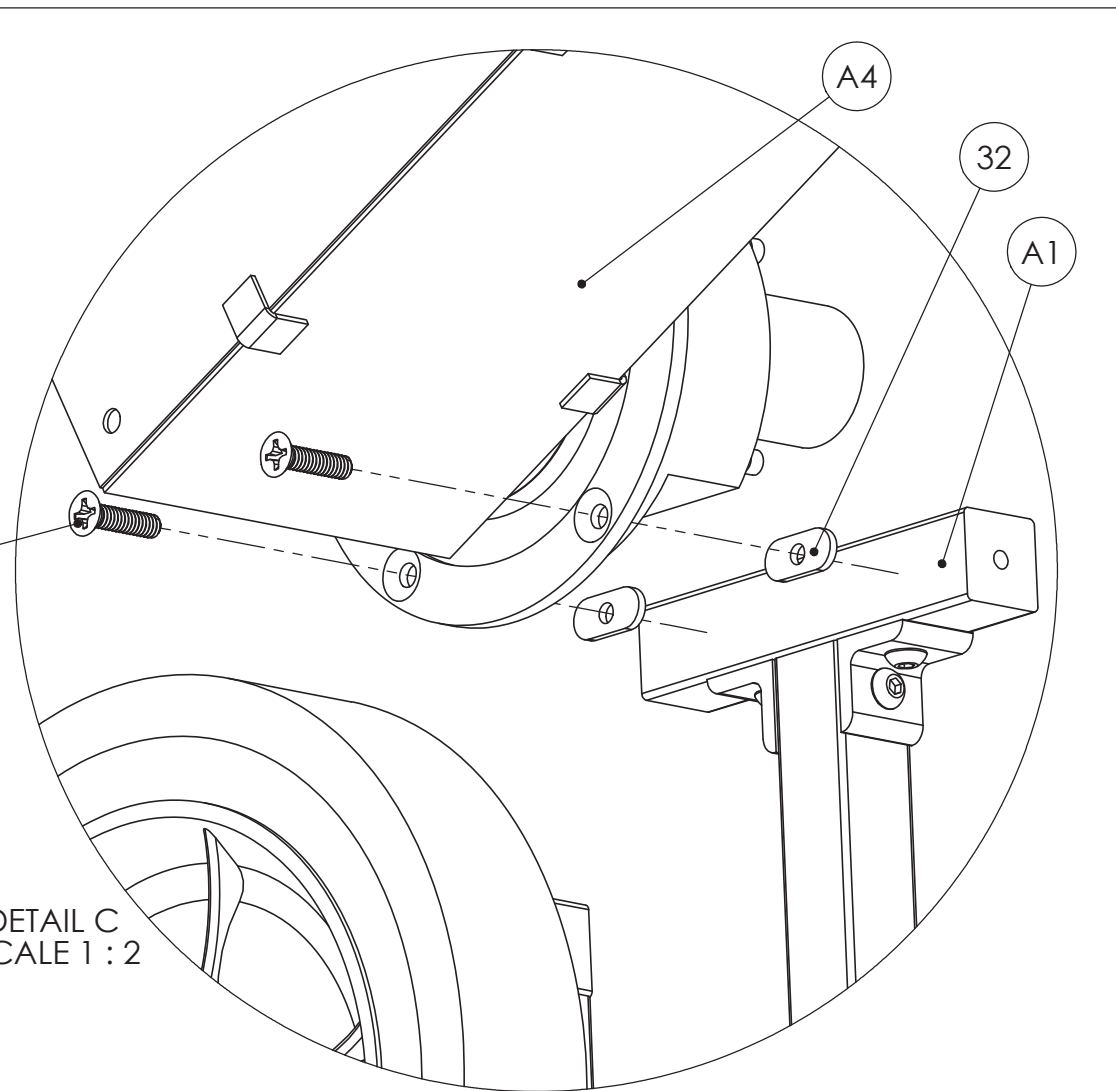

DETAIL C
SCALE 1 : 2

- NOTES:
 1. SOME COMPONENTS HIDDEN FOR CLARITY
 2. QTY: 1

TITLE:				Design Assembly	
DRAWN				[Redacted]	
DESIGNED				[Redacted]	
TOLERANCE UNLESS NOTED		SIZE	DWG. NO.	REV	
DIMENSION TYPE	PLACES IN DIMENSION	A	EML2322L-A-000	A	
	0.0 0.00 0.000				
LOCATIONAL	±0.050 ±0.020 ±0.005				
ANGULAR	±5 ±2 ±0.5	SCALE: 1:8		SHEET 5 OF 7	

ITEM NO.	PART NUMBER	DESCRIPTION	QTY.
A1	EML2322L-A-100	Mobile Platform	1
A4	EML2322L-A-200	Ball Collector	1
A5	EML2322L-A-300	Hopper	1
A6	EML2322L-A-400	Ball Dispenser	1
28	EML2322L- 501	0.25-20 1" countersunk phillips screw	2
29	EML2322L-502	0.25-20 Button Head Cap Screw	4
32	EML2322L-505	80/20 0.25-20 T-NUT	6

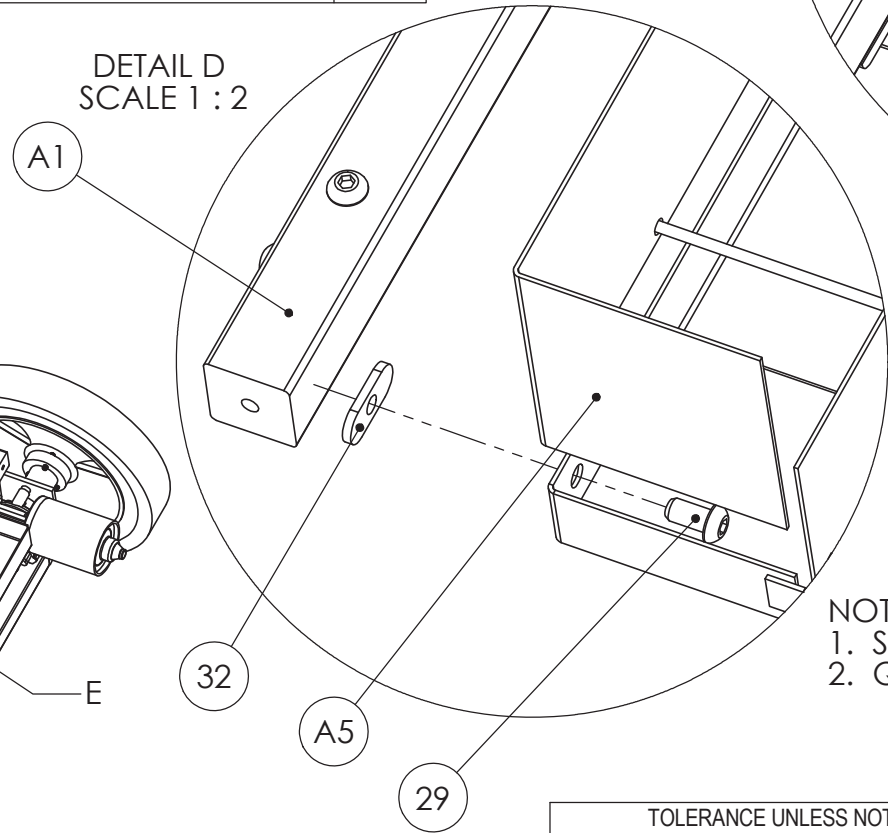
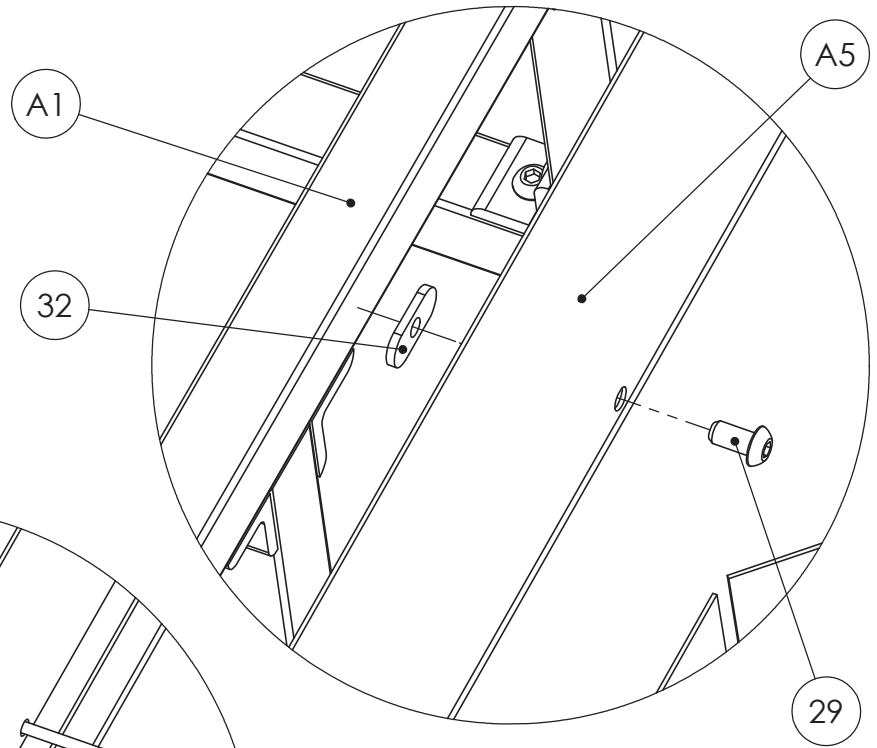

DETAIL E
SCALE 1 : 2

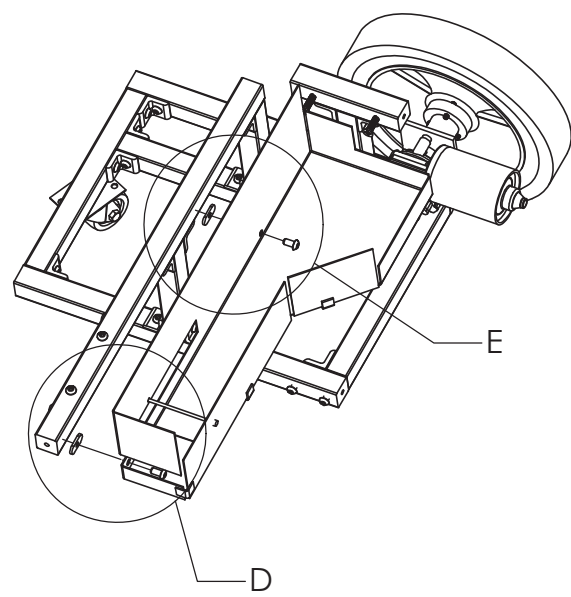

NOTES:
1. SOME COMPONENTS HIDDEN FOR CLARITY
2. QTY: 1

TITLE: Design Assembly

DRAWN: [Redacted]
DESIGNED: [Redacted]

SIZE: A DWG. NO. EML2322L-A-000 REV: A

DIMENSION TYPE	TOLERANCE UNLESS NOTED		
	PLACES IN DIMENSION		
	0.0	0.00	0.000
LOCATIONAL	±0.050	±0.020	±0.005
ANGULAR	±5	±2	±0.5

SCALE: 1:8 SHEET 6 OF 7

ITEM NO.	PART NUMBER	DESCRIPTION	QTY.
A1	EML2322L-A-100	Mobile Platform	1
A4	EML2322L-A-200	Ball Collector	1
A5	EML2322L-A-300	Hopper	1
A6	EML2322L-A-400	Ball Dispenser	1
28	EML2322L- 501	0.25-20 1" countersunk phillips screw	2
29	EML2322L-502	0.25-20 Button Head Cap Screw	4
32	EML2322L-505	80/20 0.25-20 T-NUT	6

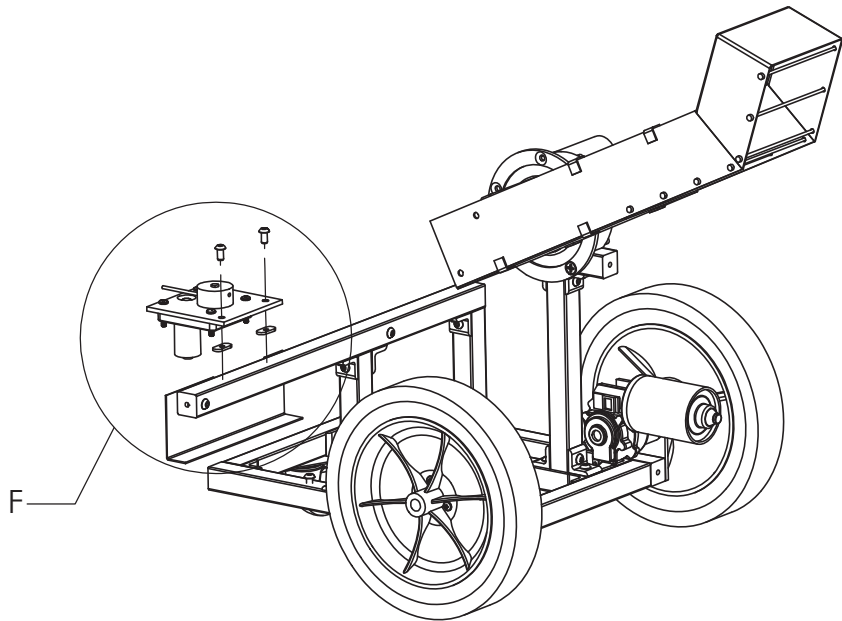
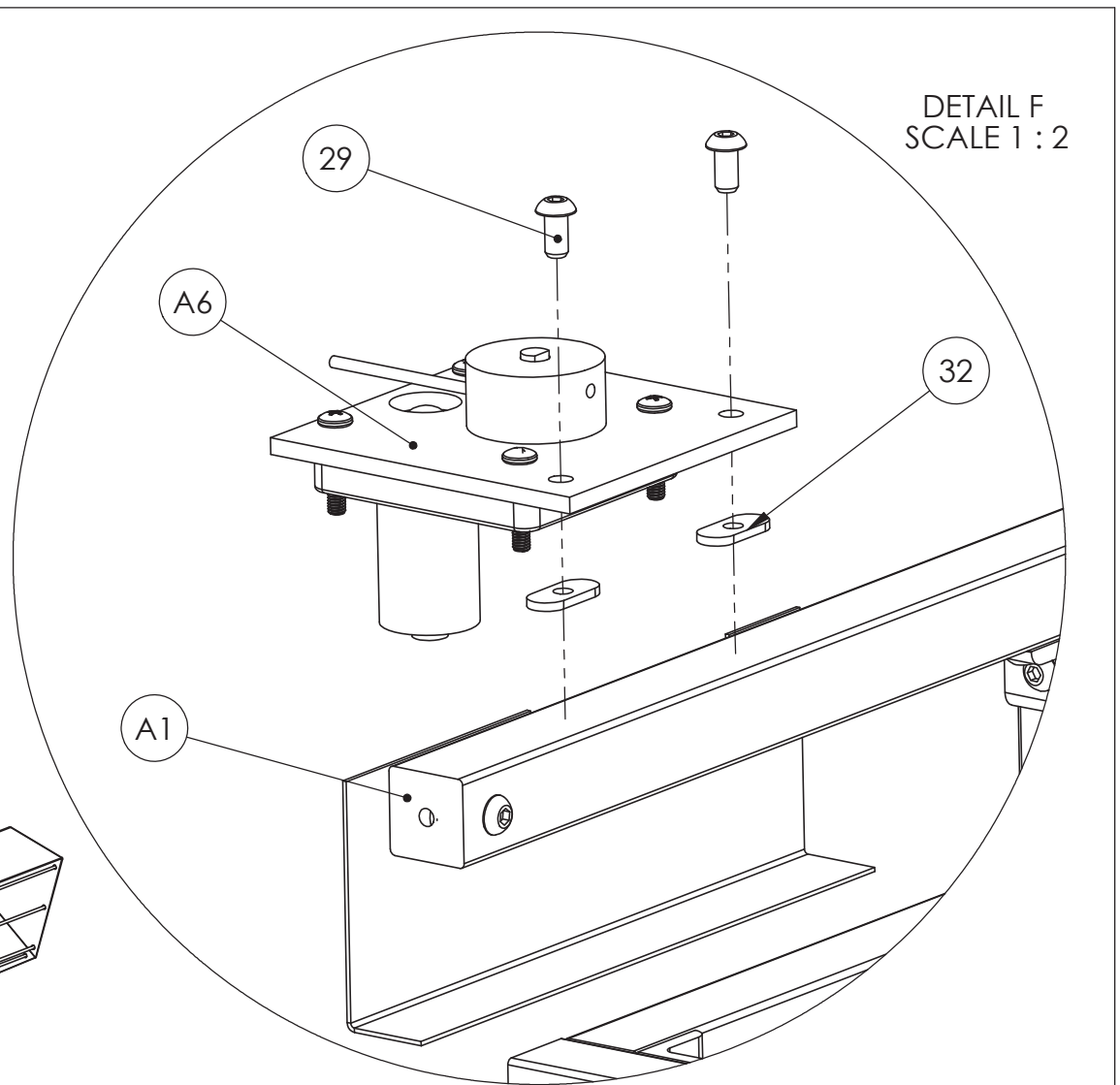

NOTES:
 1. SOME COMPONENTS HIDDEN FOR CLARITY
 2. QTY: 1

TITLE:				Design Assembly		
DRAWN				[Redacted]		
DESIGNED				[Redacted]		
TOLERANCE UNLESS NOTED		SIZE	DWG. NO.		REV	
DIMENSION TYPE	PLACES IN DIMENSION	A	EML2322L-A-000		A	
	0.0 0.00 0.000					
LOCATIONAL	±0.050 ±0.020 ±0.005	SCALE: 1:8		SHEET 7 OF 7		
ANGULAR	±5 ±2 ±0.5					

5

↑

4

3

2

1

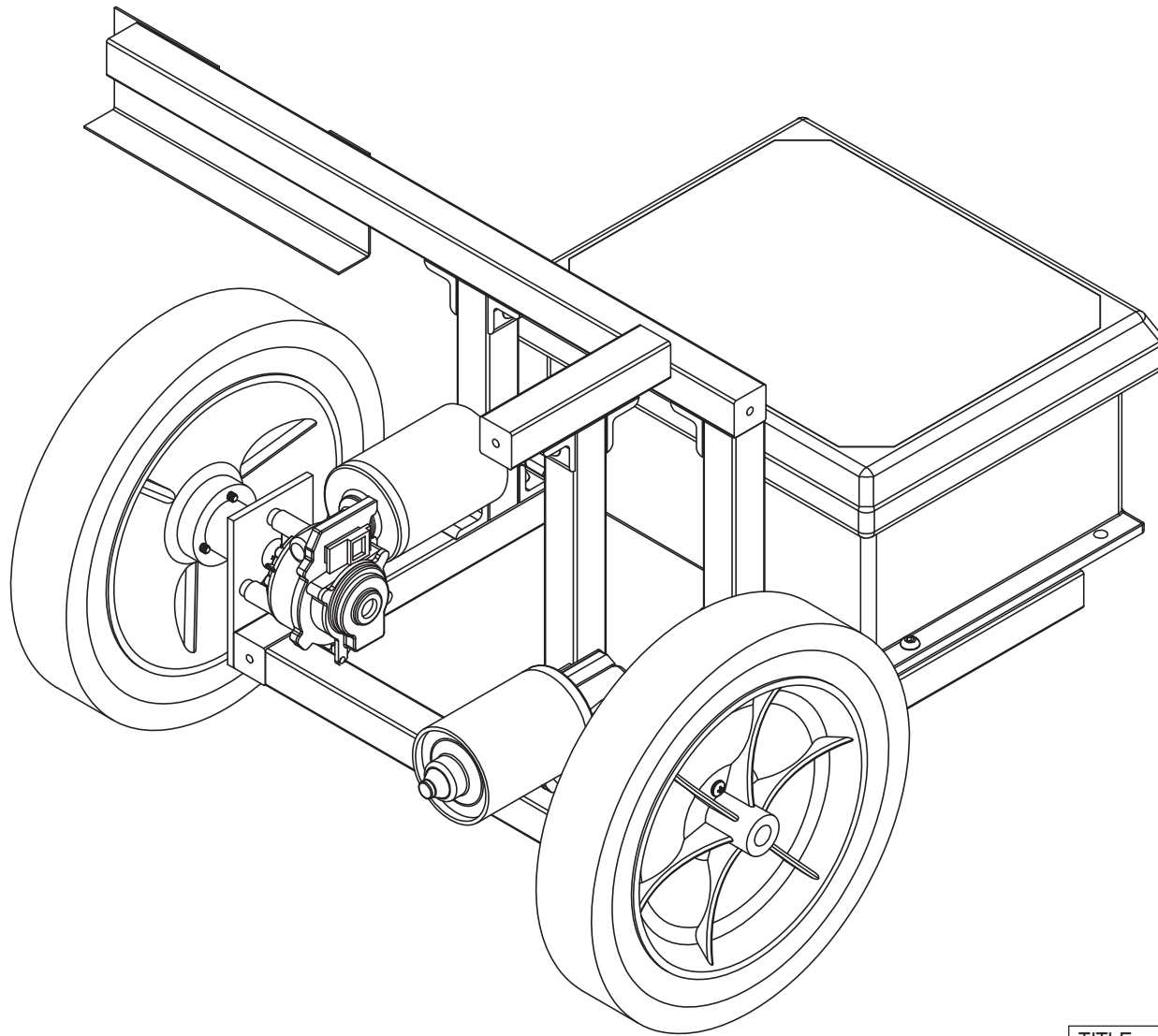

NOTES:
 1. ALL DIMS INCHES
 2. QTY: 1

TITLE:		Mobile Platform	
DRAWN			
DESIGNED			
SIZE	DWG. NO.	REV	
A	EML2322L-A-100	A	
SCALE: 1:4			SHEET 1 OF 6

DIMENSION TYPE	PLACES IN DIMENSION		
	0.0	0.00	0.000
LOCATIONAL	±0.050	±0.020	±0.005
ANGULAR	±5	±2	±0.5

5



4

3

2

1

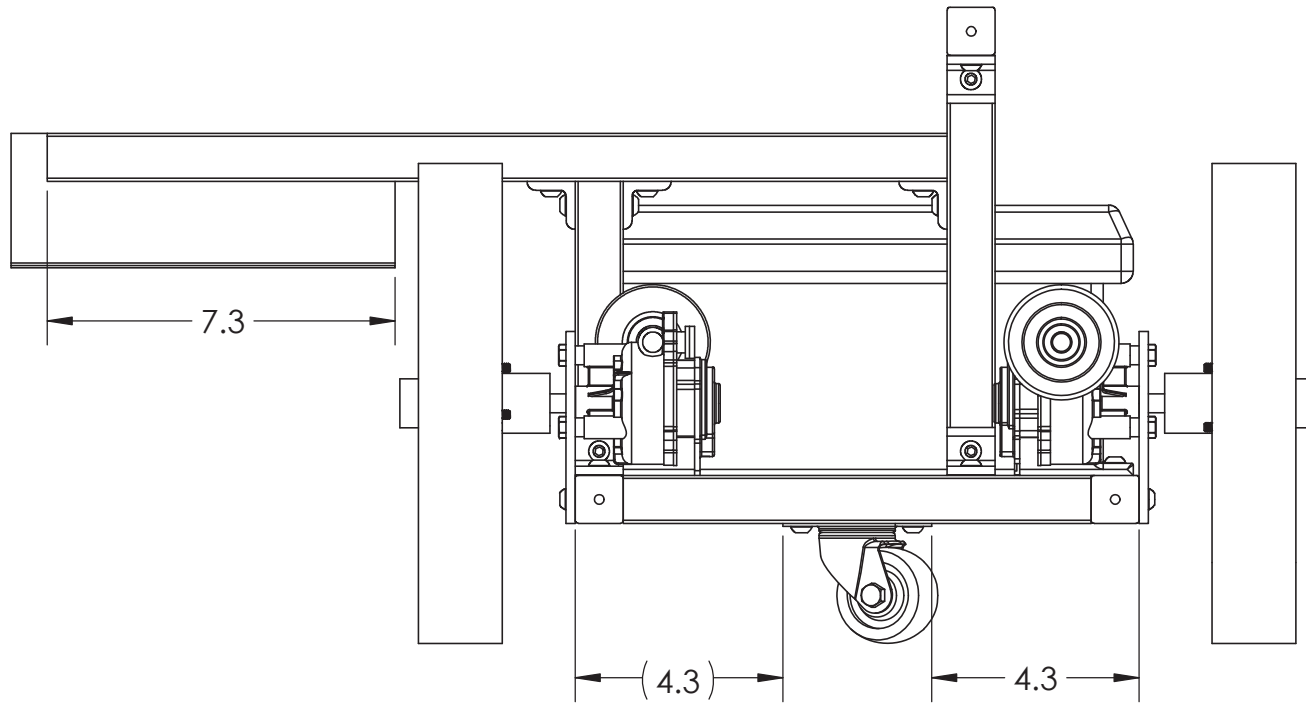

NOTES:
 1. ALL DIMS INCHES
 2. QTY: 1

TITLE:		Mobile Platform		
DRAWN	[Redacted]			
DESIGNED	[Redacted]			
SIZE	DWG. NO.		REV	
A	EML2322L-A-100		A	
SCALE: 1:4			SHEET 2 OF 6	

DIMENSION TYPE	TOLERANCE UNLESS NOTED		
	PLACES IN DIMENSION		
	0.0	0.00	0.000
LOCATIONAL	±0.050	±0.020	±0.005
ANGULAR	±5	±2	±0.5

5



4

3

2

1

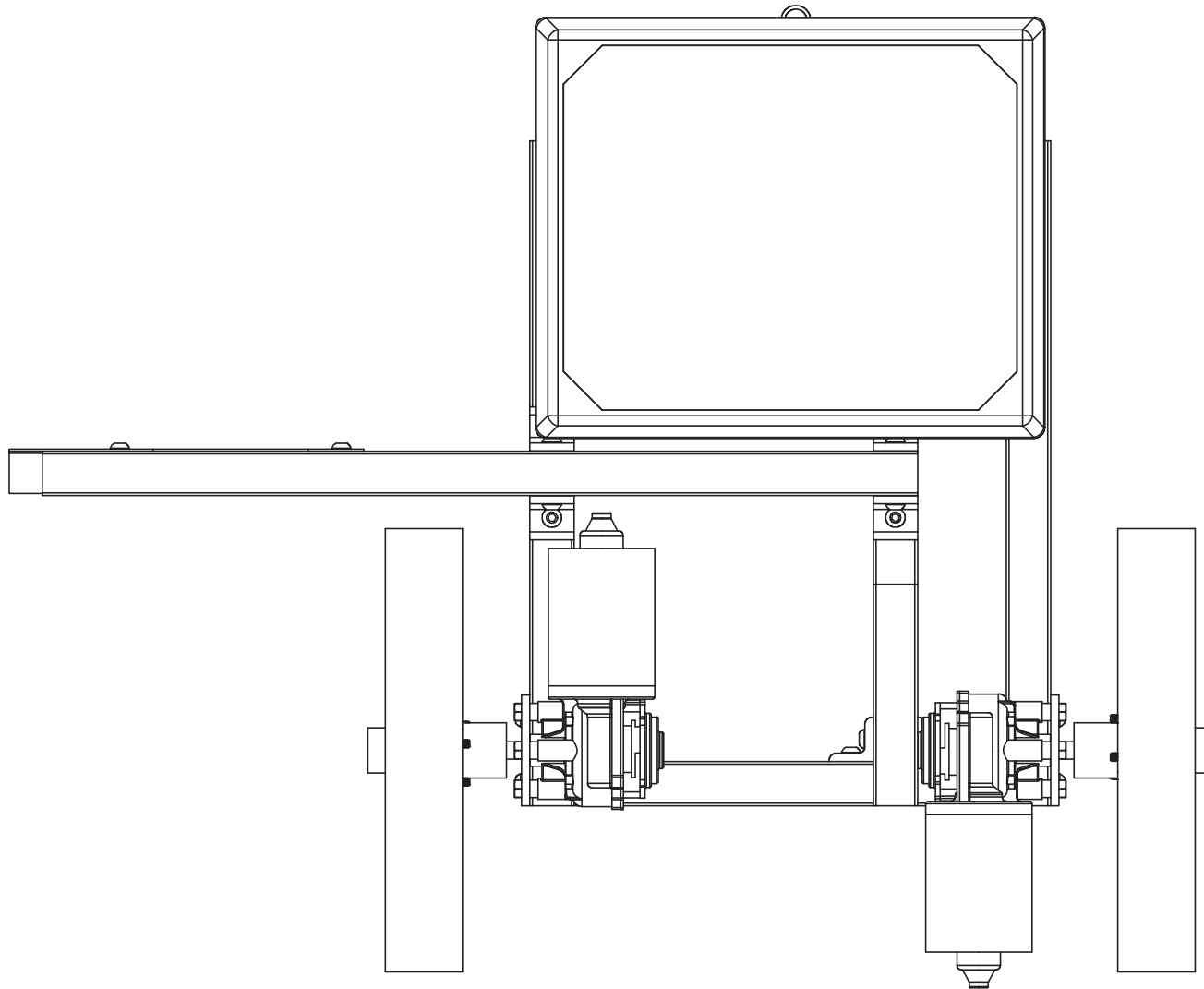

NOTES:
 1. ALL DIMS INCHES
 2. QTY: 1

TITLE:	Mobile Platform
DRAWN	
DESIGNED	

TOLERANCE UNLESS NOTED				SIZE	DWG. NO.	REV
DIMENSION TYPE	PLACES IN DIMENSION					
	0.0	0.00	0.000	A	EML2322L-A-100	A
LOCATIONAL	±0.050	±0.020	±0.005			
ANGULAR	±5	±2	±0.5			

SCALE: 1:4 SHEET 3 OF 6

5



4

3

2

1

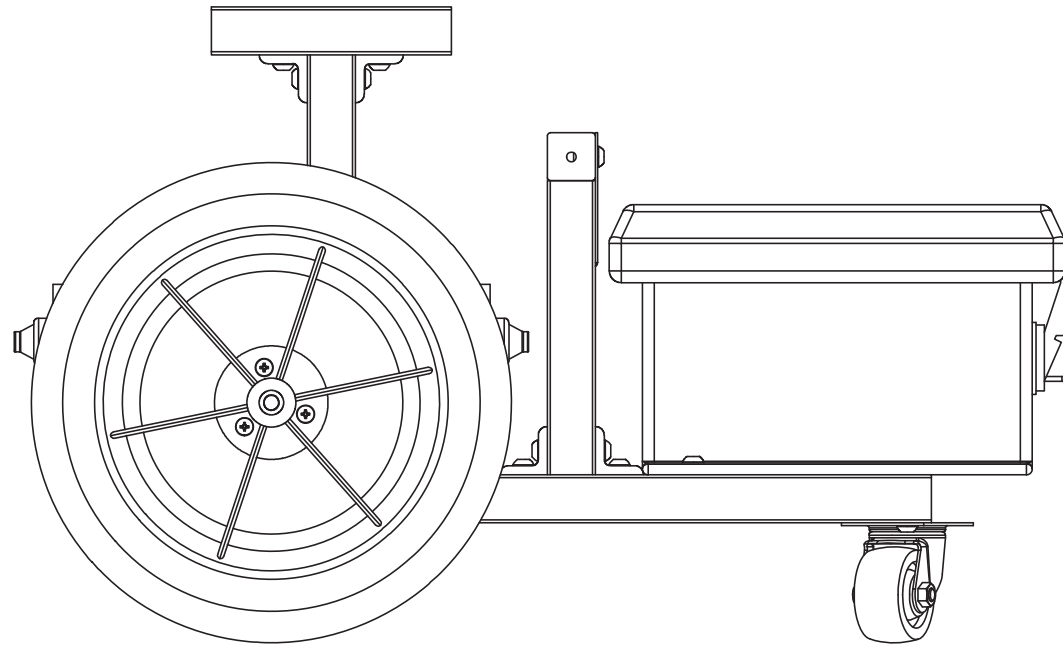

NOTES:
 1. ALL DIMS INCHES
 2. QTY: 1

TITLE:				Mobile Platform		
DRAWN		[Redacted]				
DESIGNED		[Redacted]				
DIMENSION TYPE		PLACES IN DIMENSION		SIZE	DWG. NO.	REV
		0.0	0.00	0.000	A	EML2322L-A-100
LOCATIONAL		±0.050	±0.020	±0.005		
ANGULAR		±5	±2	±0.5		
SCALE: 1:4				SHEET 4 OF 6		

5



4

3

2

1

ITEM NO.	PART NUMBER	DESCRIPTION	QTY.
A2	EML2322L-A-110	Drive Assembly	2
A3	EML2322L-A-120	Frame Assembly	1
1	EML2322L-101	Control Box	1
2	EML2322L-102	2.5" Swivel Caster	1
3	EML2322L-103	Bucket Stabilizer	1
29	EML2322L-502	X 0.25-20 Button Head Cap Screw	10
32	EML2322L-505	80/20 0.25-20 T-NUT	10

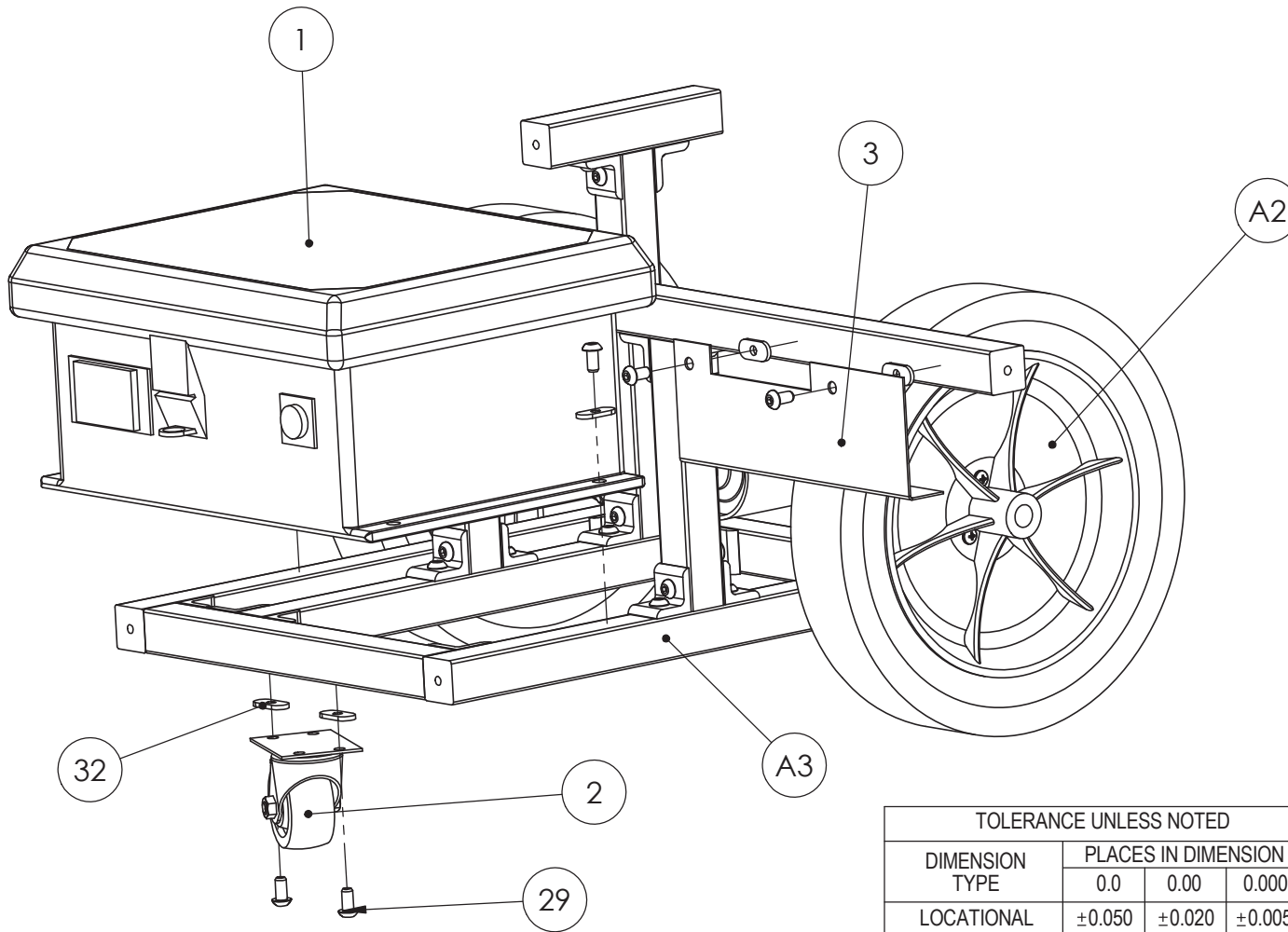

NOTES:
 1. ALL DIMS INCHES
 2. QTY: 1

TITLE:		Mobile Platform	
DRAWN	[Redacted]		
DESIGNED	[Redacted]		
SIZE	DWG. NO.	REV	
A	EML2322L-A-100	A	
SCALE: 1:4		SHEET 5 OF 6	

DIMENSION TYPE	PLACES IN DIMENSION		
	0.0	0.00	0.000
LOCATIONAL	±0.050	±0.020	±0.005
ANGULAR	±5	±2	±0.5

ITEM NO.	PART NUMBER	DESCRIPTION	QTY.
A2	EML2322L-A-110	Drive Assembly	2
A3	EML2322L-A-120	Frame Assembly	1
1	EML2322L-101	Control Box	1
2	EML2322L-102	2.5" Swivel Caster	1
3	EML2322L-103	Bucket Stabilizer	1
29	EML2322L-502	X 0.25-20 Button Head Cap Screw	10
32	EML2322L-505	80/20 0.25-20 T-NUT	10

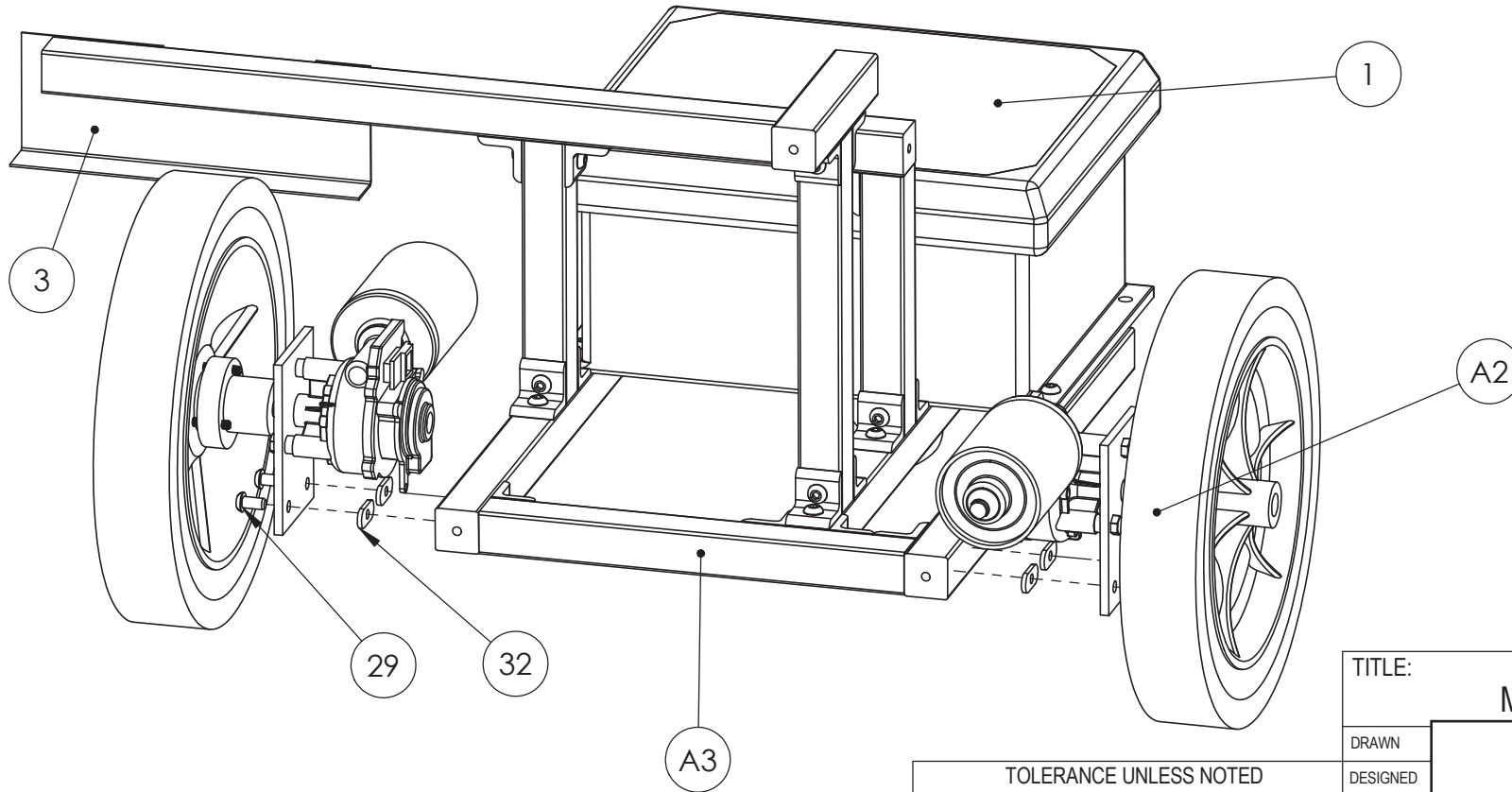

NOTES:
 1. ALL DIMS INCHES
 2. QTY: 1

TITLE:				Mobile Platform	
DRAWN				[Redacted]	
DESIGNED				[Redacted]	
SIZE	DWG. NO.			REV	
A	EML2322L-A-100			A	
SCALE: 1:4			SHEET 6 OF 6		

DIMENSION TYPE	PLACES IN DIMENSION		
	0.0	0.00	0.000
LOCATIONAL	±0.050	±0.020	±0.005
ANGULAR	±5	±2	±0.5

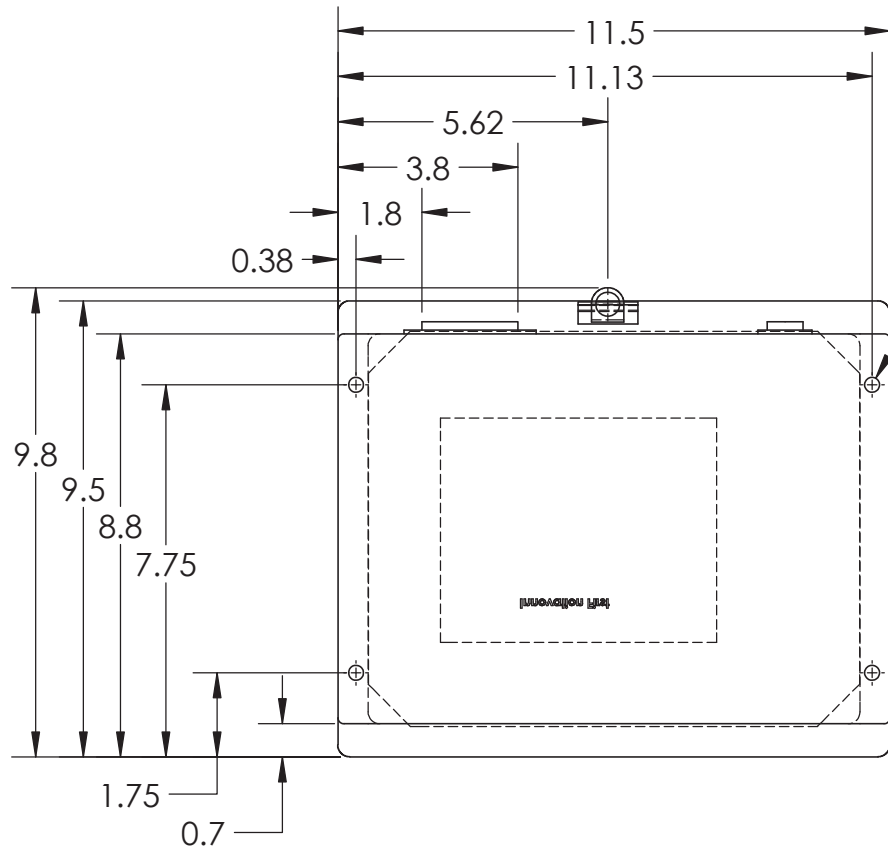
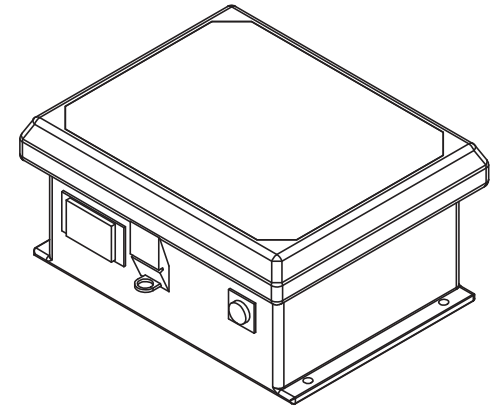
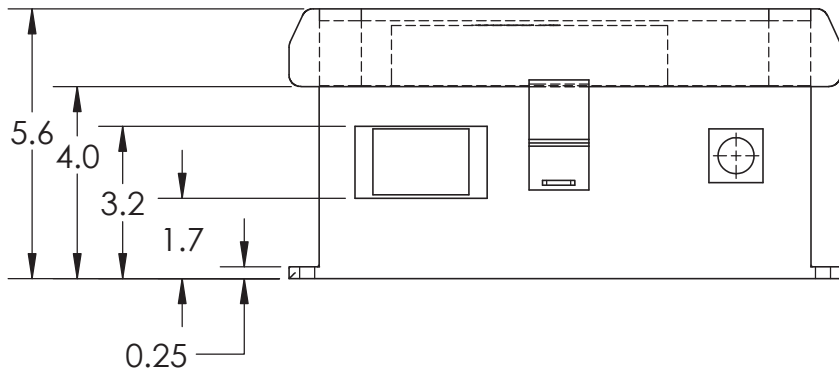

Ø0.313 THRU;
4 PLACES

- NOTES:
 1. DIMS IN INCHES
 2. QTY SPECIFIED IN BOM
 3. DIMS AND MAT'L SPECIFIED BY MANUFACTURER

TOLERANCE UNLESS NOTED				TITLE:		
MEASURING INSTRUMENT	PLACES IN DIMENSION			Control Box		
	0.0	0.00	0.000			
CALIPERS	/	/	±0.005	DESIGNED	INNOVATION FIRST	
PRECISION RULER	/	±0.015	/	SIZE	DWG. NO.	REV
TAPE MEASURE	±0.030	/	/	A	EML2322L-101	A
PROTRACTOR	±10	±5	±2	SCALE: 1:4		SHEET 1 OF 1

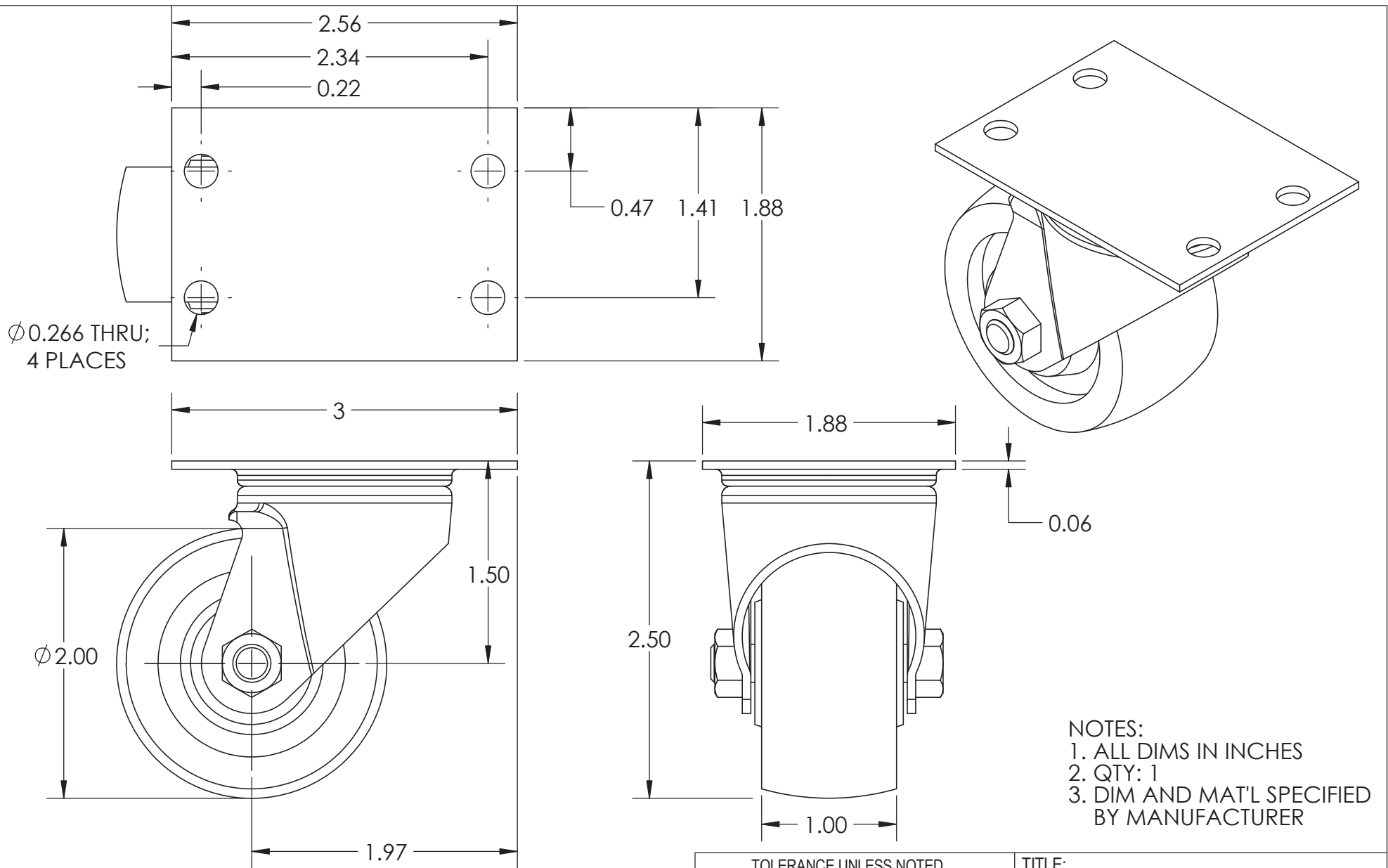

- NOTES:
1. ALL DIMS IN INCHES
 2. QTY: 1
 3. DIM AND MAT'L SPECIFIED BY MANUFACTURER

TOLERANCE UNLESS NOTED				TITLE:		
MEASURING INSTRUMENT	PLACES IN DIMENSION			2.5" Swivel Caster		
	0.0	0.00	0.000			
CALIPERS	/	/	± 0.005	DRAWN	[Redacted]	
PRECISION RULER	/	± 0.015	/	DESIGNED		
TAPE MEASURE	± 0.030	/	/	SIZE	DWG. NO.	REV
PROTRACTOR	± 10	± 5	± 2	A	EML2322L-102	A
				SCALE: 1:1	SHEET 1 OF 1	

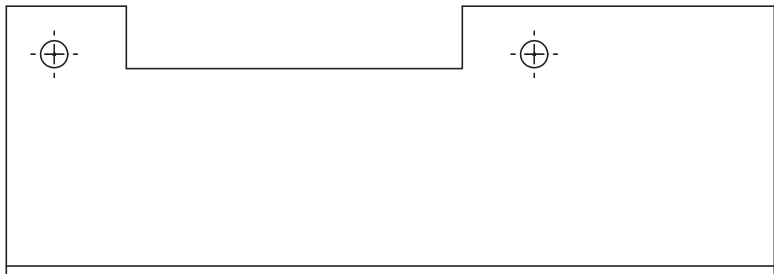
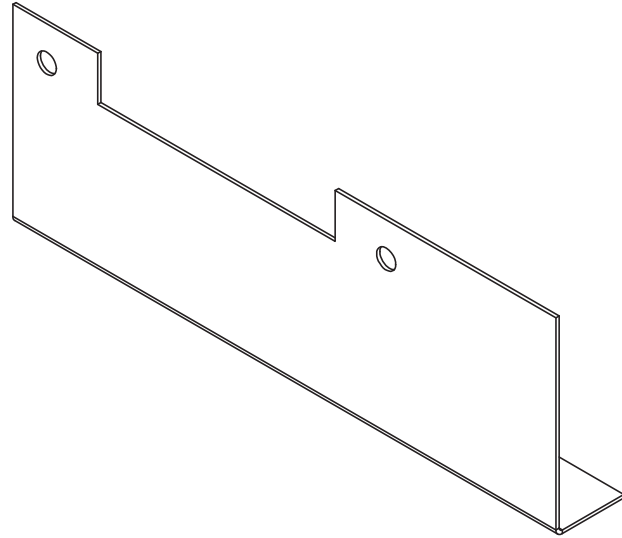

- NOTES:
 1. DIMS IN INCHES
 2. QTY: 1
 3. MAT'L: 18 GA. SHEET STEEL
 4. FINISH NOTED SURFACES
 5. BREAK ALL EDGES

FOLDED VIEW
(IF APPLICABLE)

TOLERANCE UNLESS NOTED				TITLE:		
OPERATION	PLACES IN DIMENSION			Bucket Stabilizer		
	0.0	0.00	0.000			
MACHINING	/ / / / / / / / / /			DRAWN	[Redacted]	
SHEETMETAL (SHEAR, BEND)	±0.1	±0.060	±0.030	DESIGNED		
WELDING	±0.1	±0.060	/ / / / / / / / / /	SIZE	DWG. NO.	REV
ANGULAR DIMS	±5	±2	/ / / / / / / / / /	A	EML2322L-103	A
				SCALE: 1:2		SHEET 1 OF 2

5



4

3

2

1

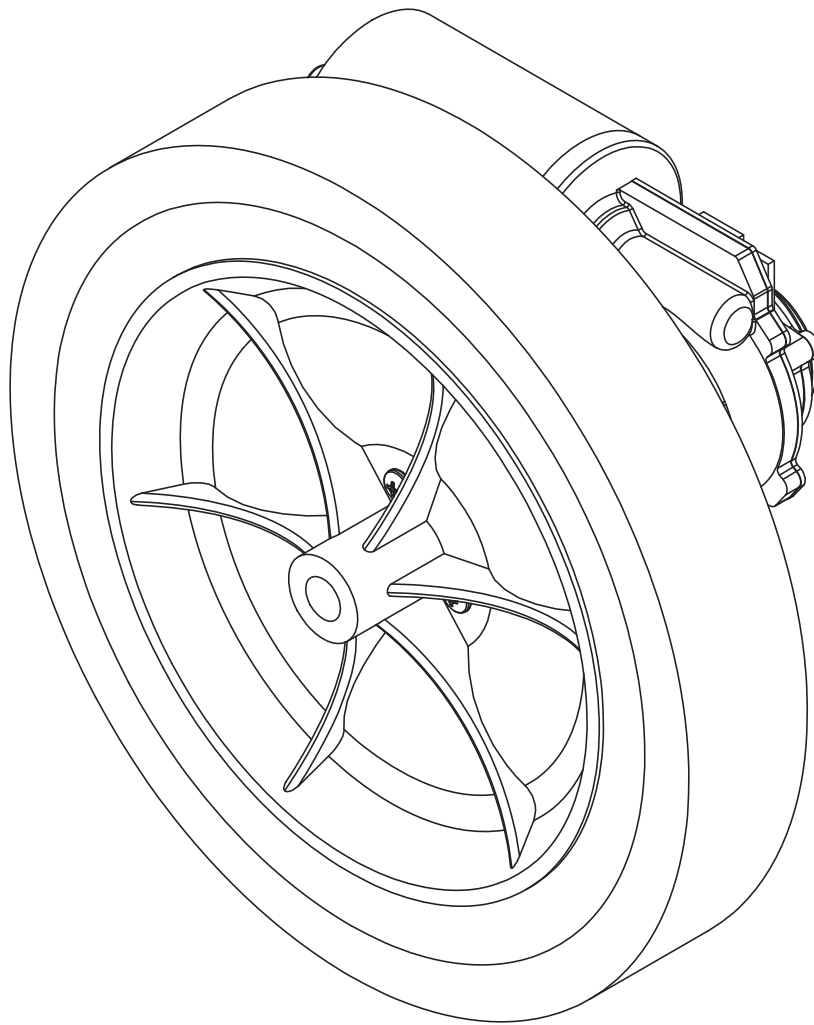

NOTES:
 1. ALL DIMS INCHES
 2. QTY: 2

TITLE:				Drive Assembly		
DRAWN				[Redacted]		
DESIGNED				[Redacted]		
SIZE	DWG. NO.				REV	
A	EML2322L-A-110				A	
SCALE: 1:2					SHEET 1 OF 3	

DIMENSION TYPE	PLACES IN DIMENSION		
	0.0	0.00	0.000
LOCATIONAL	±0.050	±0.020	±0.005
ANGULAR	±5	±2	±0.5

TOLERANCE UNLESS NOTED

5



4

3

2

1

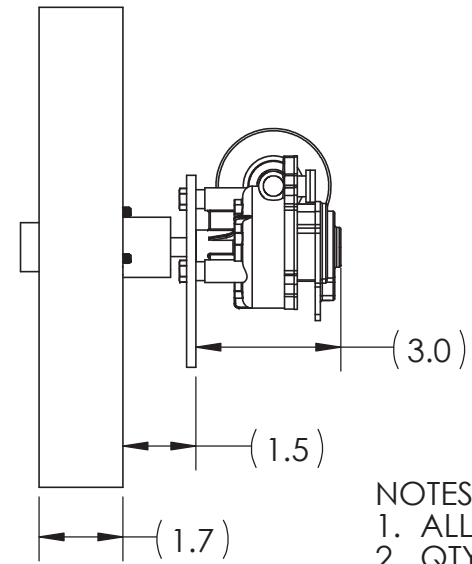
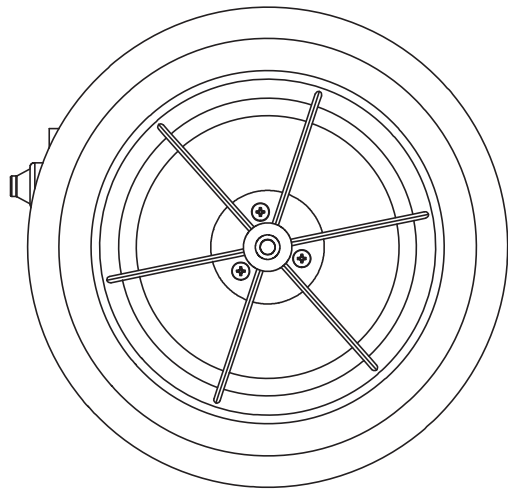
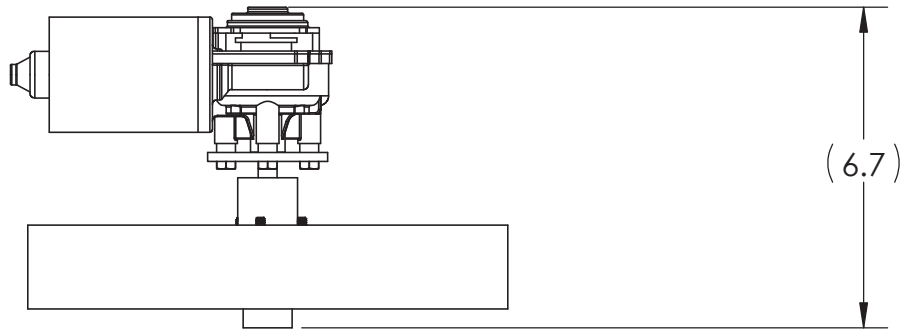

NOTES:
 1. ALL DIMS INCHES
 2. QTY: 2

TITLE: Drive Assembly

DRAWN [Redacted]
 DESIGNED [Redacted]

TOLERANCE UNLESS NOTED				SIZE	DWG. NO.	REV
DIMENSION TYPE	PLACES IN DIMENSION					
	0.0	0.00	0.000	A	EML2322L-A-110	A
LOCATIONAL	±0.050	±0.020	±0.005			
ANGULAR	±5	±2	±0.5			

SCALE: 1:4 SHEET 2 OF 3

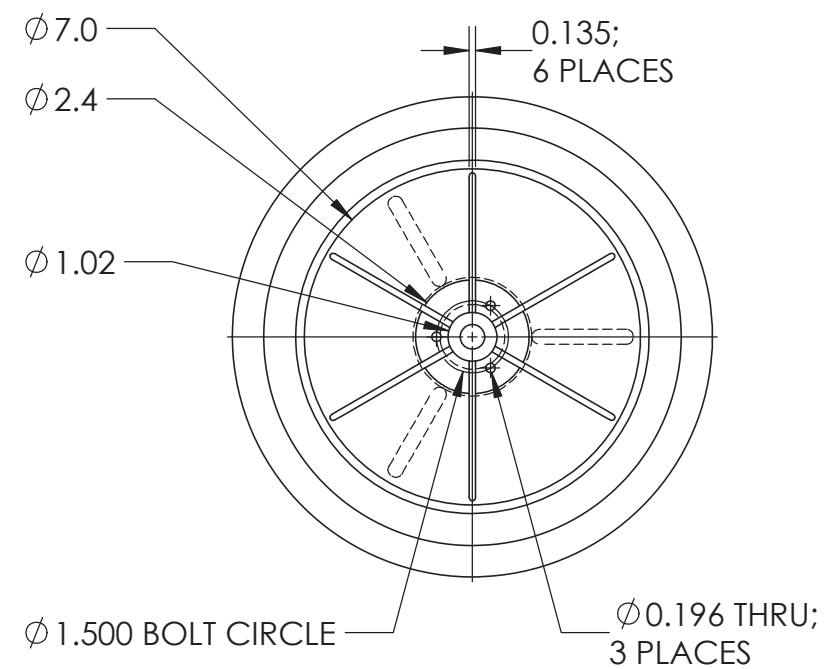
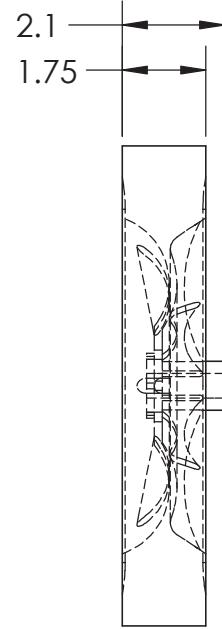
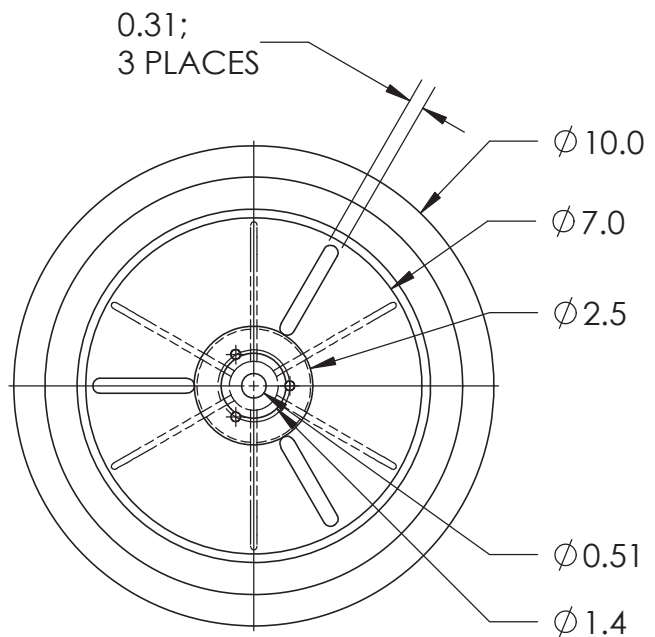
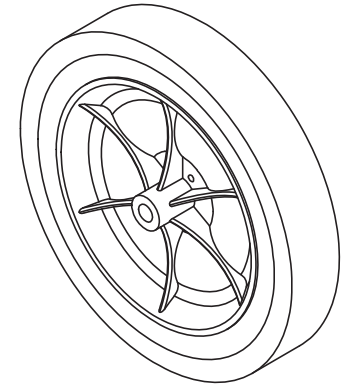

NOTES:
 1. DIMS IN INCHES
 2. QTY SPECIFIED IN BOM
 3. DIMS AND MAT'L SPECIFIED BY MANUFACTURER

TOLERANCE UNLESS NOTED				TITLE: 10 Inch Wheel		
MEASURING INSTRUMENT	PLACES IN DIMENSION			DRAWN	J. DERSCH	
	0.0	0.00	0.000			
CALIPERS	/	/	±0.005	DESIGNED	ARNOLD	
PRECISION RULER	/	±0.015	/	SIZE	DWG. NO.	REV
TAPE MEASURE	±0.030	/	/	A	EML2322L-111	A
PROTRACTOR	±10	±5	±2	SCALE: 1:4		SHEET 1 OF 2

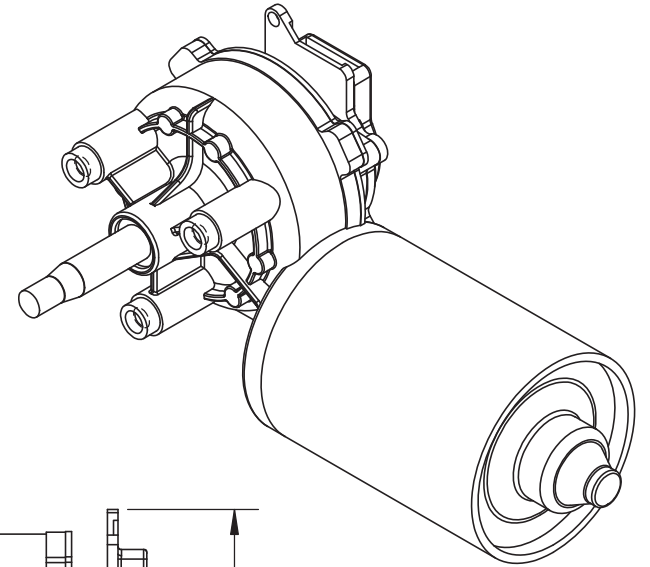
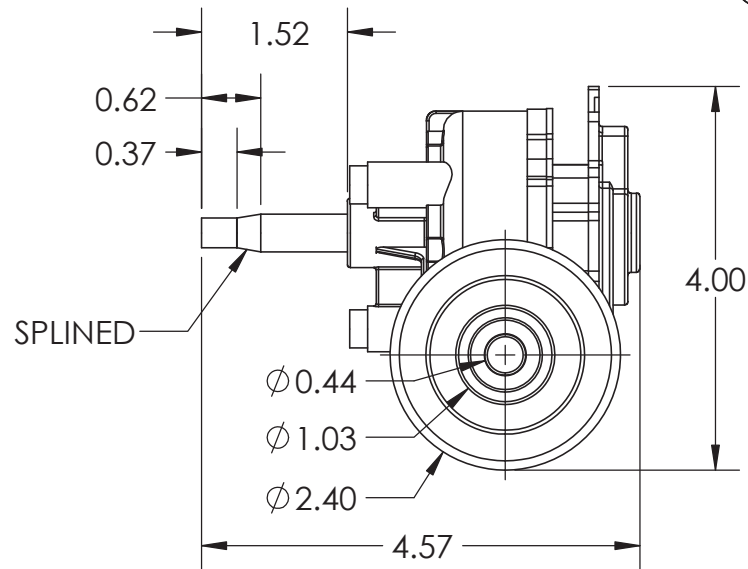
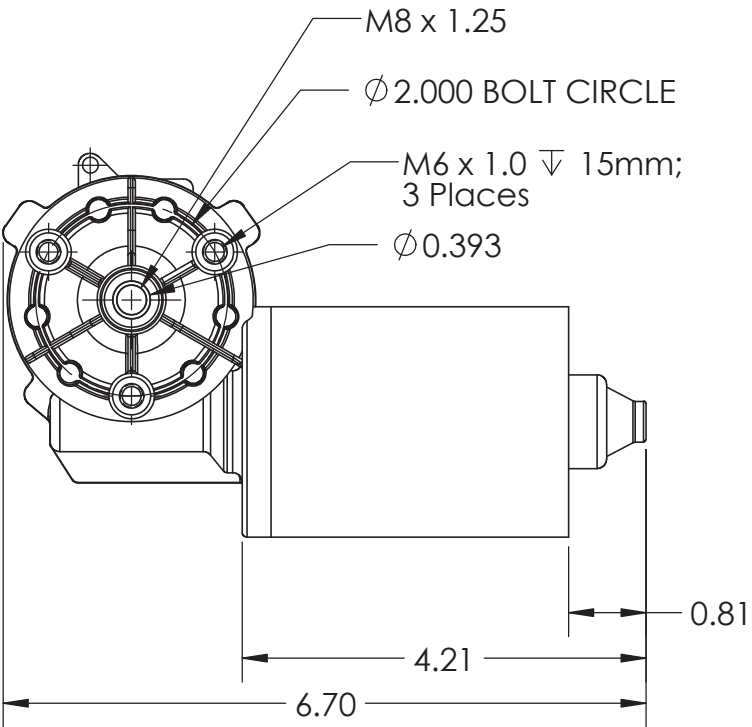

- NOTES:
1. DIMS IN INCHES
 2. QTY SPECIFIED IN BOM
 3. DIMS AND MAT'L SPECIFIED BY MANUFACTURER

TOLERANCE UNLESS NOTED				TITLE:		
MEASURING INSTRUMENT	PLACES IN DIMENSION			44 RPM Entstort Right Angle Gear Motor		
	0.0	0.00	0.000	DRAWN	J. DERSCH	
CALIPERS	/	/	±0.005	DESIGNED	ENTSTORT	
PRECISION RULER	/	±0.015	/	SIZE	DWG. NO.	REV
TAPE MEASURE	±0.030	/	/	A	EML2322L-112	A
PROTRACTOR	±10	±5	±2	SCALE: 1:2		SHEET 1 OF 1

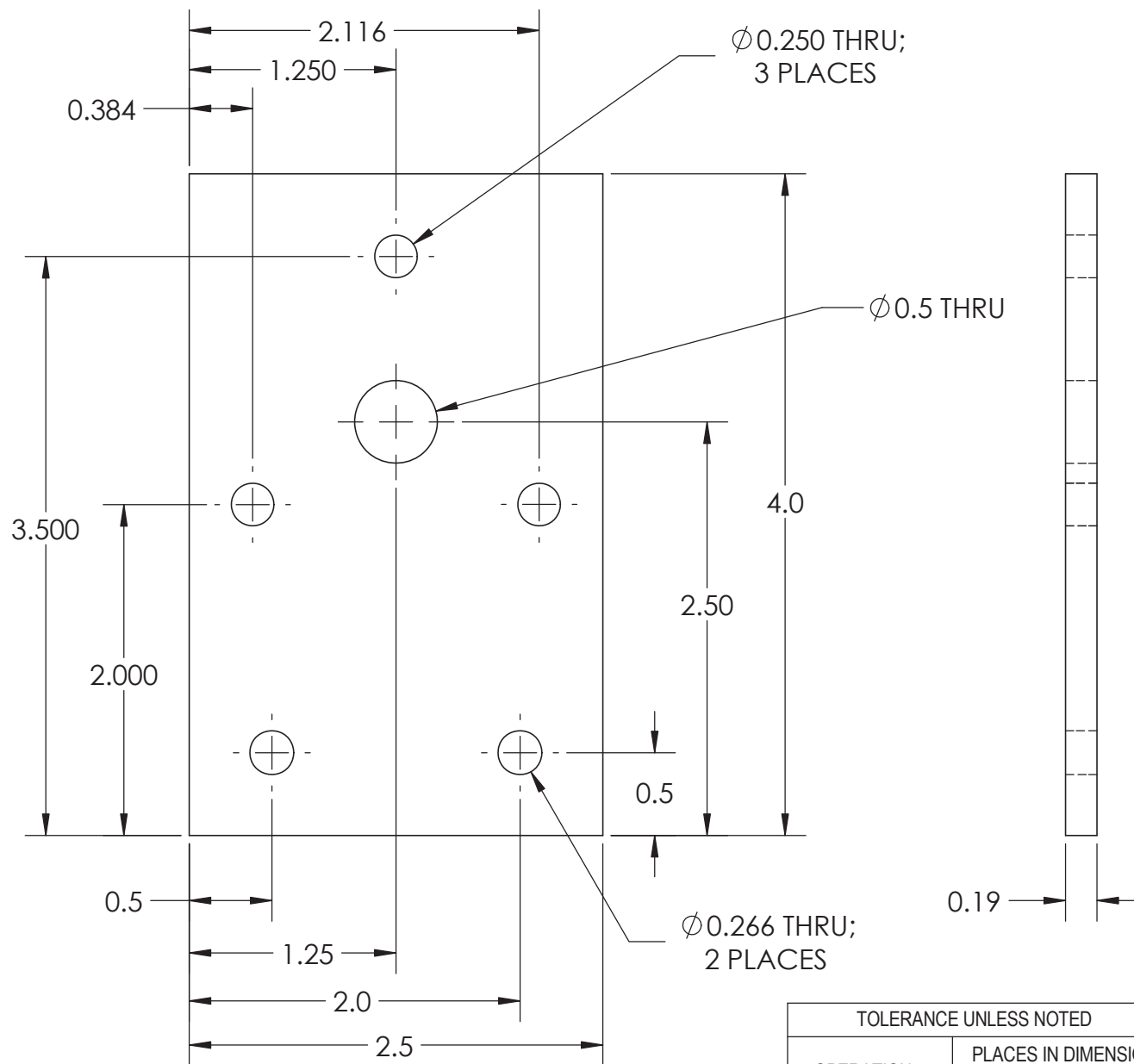

- NOTES:
 1. DIMS IN INCHES
 2. QUANTITY: 2
 3. MAT'L: ALUMINUM
 4. FINISHED NOTED SURFACES
 5. BREAK ALL EDGES

TOLERANCE UNLESS NOTED				TITLE: Enstort Motor Mount		
OPERATION	PLACES IN DIMENSION			DRAWN		
	0.0	0.00	0.000			
MACHINING	±0.050	±0.020	±0.005	DESIGNED		
CUT OFF (SAW, BURN, SHEAR)	±0.1	±0.060		SIZE	DWG. NO.	REV
WELDING	±0.1	±0.060		A	EML2322L-113	A
ANGULAR DIMS	±5	±2	±0.5	SCALE: 1:1		SHEET 1 OF 1

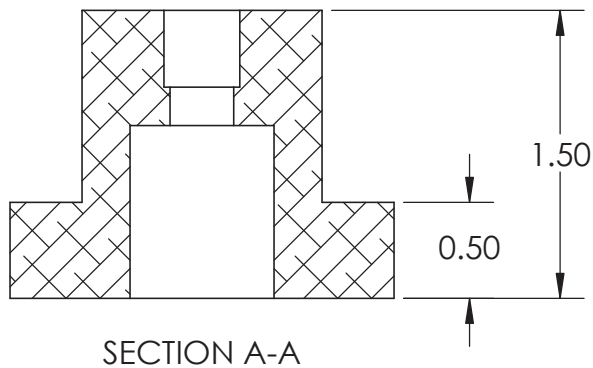
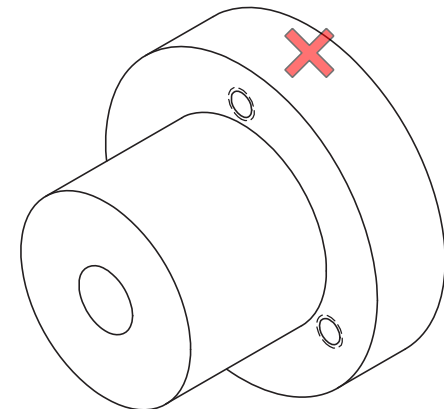
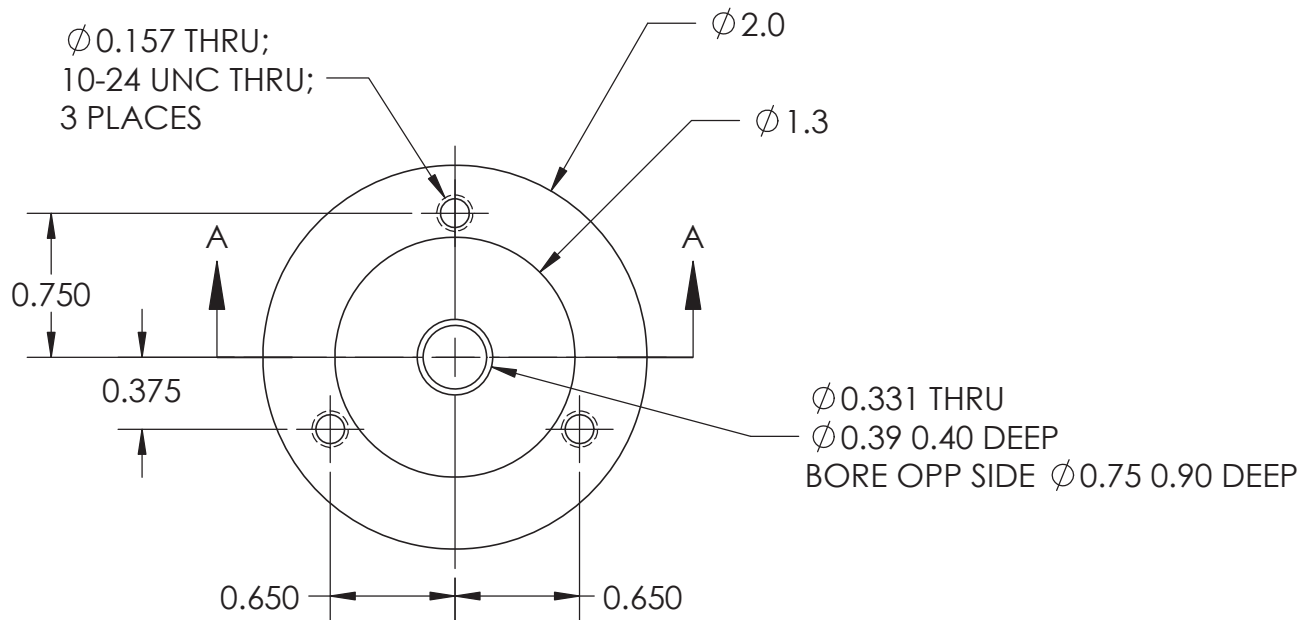

- NOTES:
1. QTY: 2
 2. ALL DIMS IN INCHES
 3. MAT'L: ALUMINUM
 4. FINISHED NOTED SURFACES
 5. BREAK ALL EDGES

TOLERANCE UNLESS NOTED				TITLE: Enstort Wheel Hub			
OPERATION	PLACES IN DIMENSION			DRAWN	DWG. NO. EML2322L-114		REV
	0.0	0.00	0.000				
MACHINING	± 0.050	± 0.020	± 0.005	DESIGNED	A		A
CUT OFF (SAW, BURN, SHEAR)	± 0.1	± 0.060		SIZE			
WELDING	± 0.1	± 0.060		SCALE: 1:1	SHEET 1 OF 1		
ANGULAR DIMS	± 5	± 2	± 0.5				

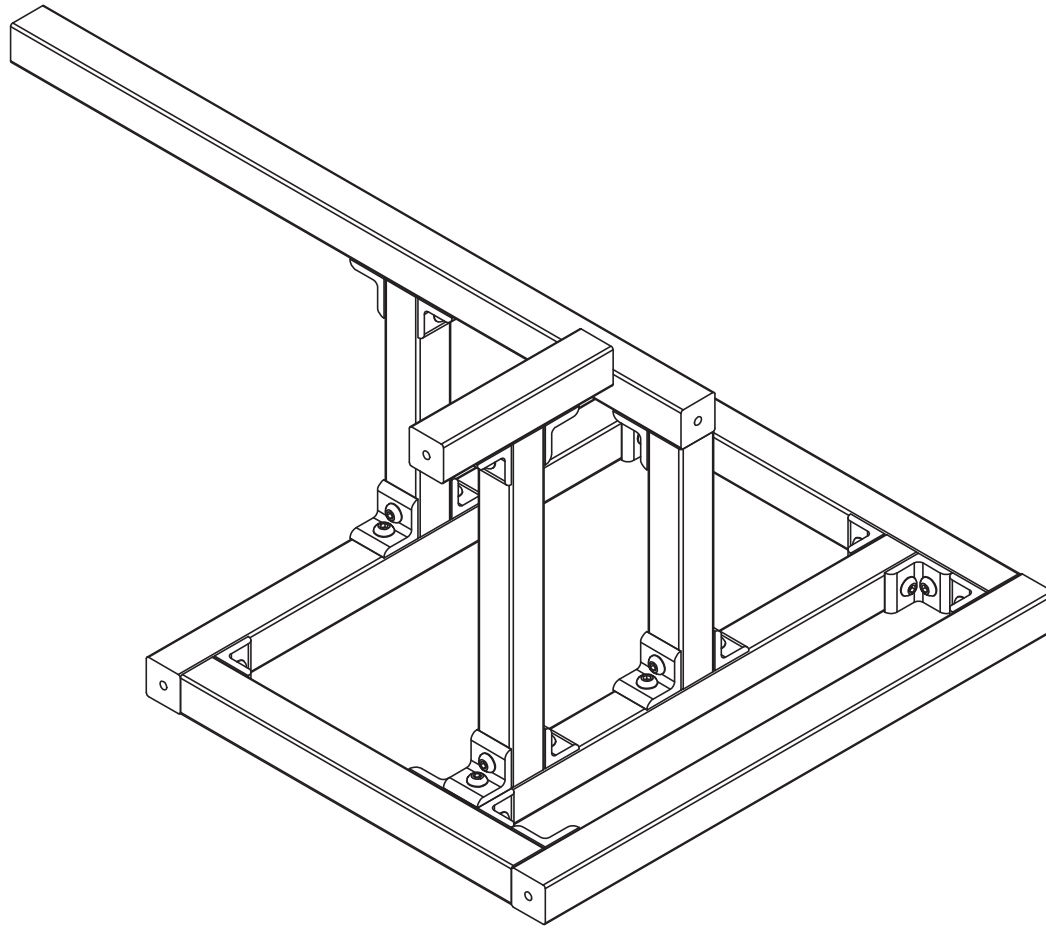

- NOTES:
 1. DIMS IN INCHES
 2. QTY: 1

TITLE:			
Frame Assembly			
DRAWN			
DESIGNED			
SIZE	DWG. NO.	REV	
A	EML2322L-A-120	A	
SCALE: 1:4		SHEET 1 OF 5	

DIMENSION TYPE	TOLERANCE UNLESS NOTED		
	PLACES IN DIMENSION		
	0.0	0.00	0.000
LOCATIONAL	±0.050	±0.020	±0.005
ANGULAR	±5	±2	±0.5

5



4

3

2

1

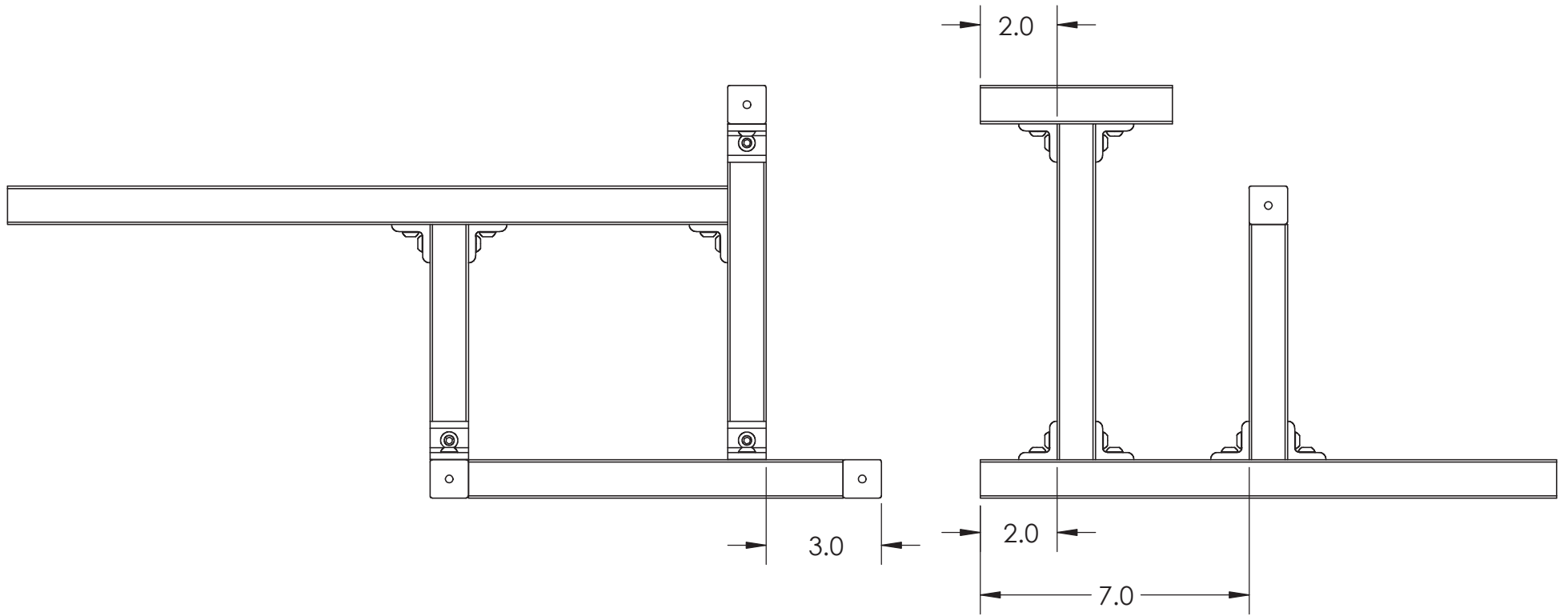

NOTES:
 1. DIMS IN INCHES
 2. QTY: 1

TITLE:				Frame Assembly	
DRAWN				[Redacted]	
DESIGNED				[Redacted]	
SIZE		DWG. NO.		REV	
A		EML2322L-A-120		A	
SCALE: 1:4			SHEET 2 OF 5		

DIMENSION TYPE	PLACES IN DIMENSION		
	0.0	0.00	0.000
LOCATIONAL	±0.050	±0.020	±0.005
ANGULAR	±5	±2	±0.5

5



4

3

2

1

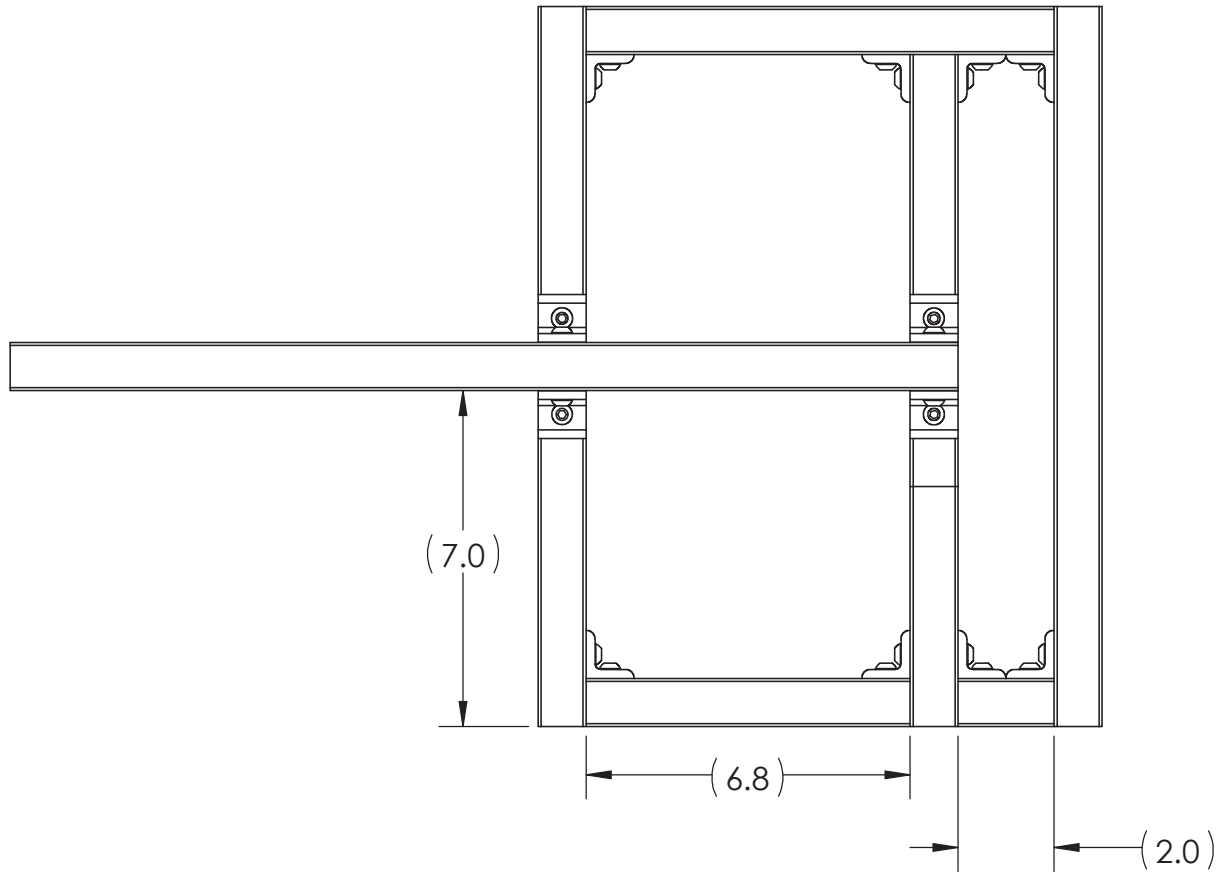

NOTES:
 1. DIMS IN INCHES
 2. QTY: 1

TITLE:				Frame Assembly		
DRAWN				[Redacted]		
DESIGNED				[Redacted]		
TOLERANCE UNLESS NOTED		SIZE	DWG. NO.		REV	
DIMENSION TYPE	PLACES IN DIMENSION			A	EML2322L-A-120	A
	0.0	0.00	0.000			
LOCATIONAL	±0.050	±0.020	±0.005			
ANGULAR	±5	±2	±0.5	SCALE: 1:4	SHEET 3 OF 5	

ITEM NO.	PART NUMBER	DESCRIPTION	QTY.
8	EML2322L-121	80/20 Extrusion, 5"	1
9	EML2322L-122	80/20 Extrusion, 6.1"	2
10	EML2322L-123	80/20 Extrusion, 8.8"	1
11	EML2322L-124	80/20 Extrusion, 9.8"	2
12	EML2322L-125	80/20 Extrusion, 13"	1
13	EML2322L-126	80/20 Extrusion, 15"	2
14	EML2322L-127	80/20 Extrusion, 19.8"	1
29	EML2322L-502	0.25-20 button head cap screw	38
32	EML2322L-505	80/20 0.25-20 T-nut	38
33	EML2322L-506	80/20 90 Degree Angle Bracket	19

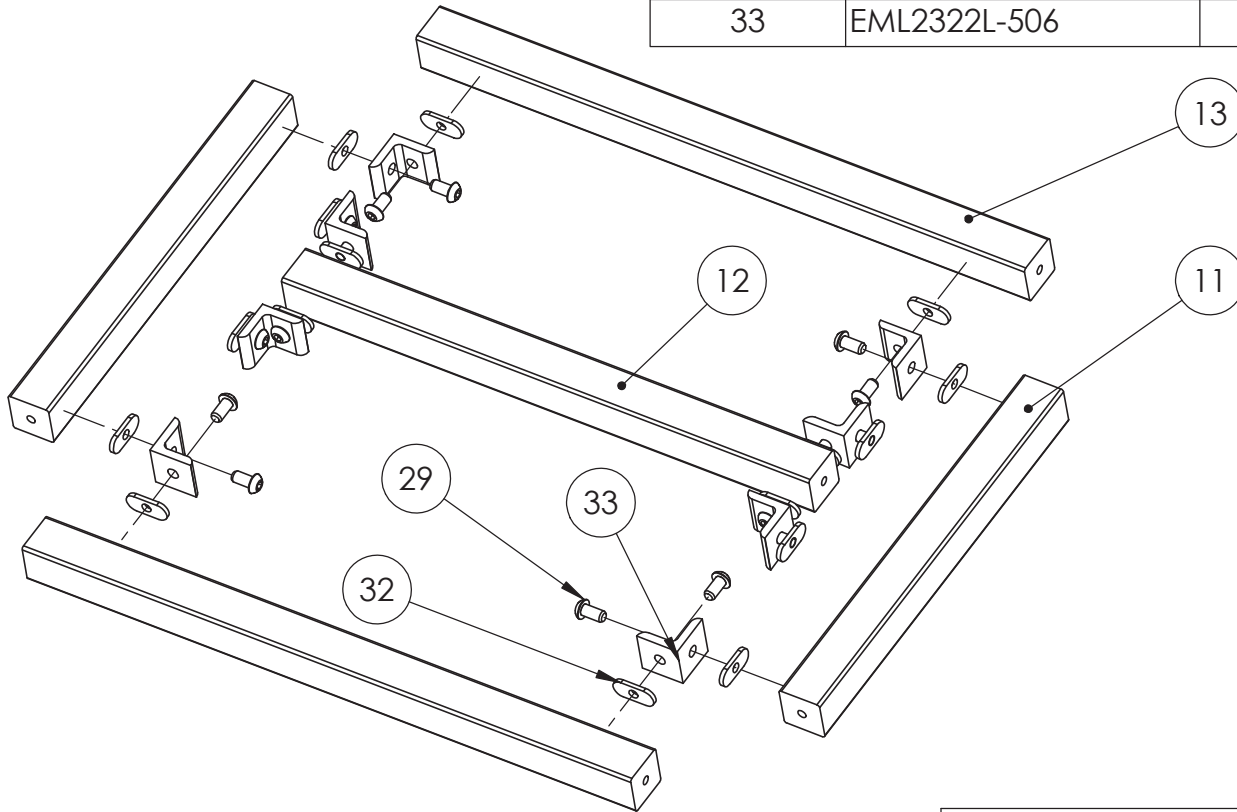

NOTES:
 1. DIMS IN INCHES
 2. QTY: 1

TITLE:				Frame Assembly	
DRAWN					
DESIGNED					
SIZE	DWG. NO.			REV	
A	EML2322L-A-120			A	
SCALE: 1:4			SHEET 4 OF 5		

DIMENSION TYPE	PLACES IN DIMENSION		
	0.0	0.00	0.000
LOCATIONAL	±0.050	±0.020	±0.005
ANGULAR	±5	±2	±0.5

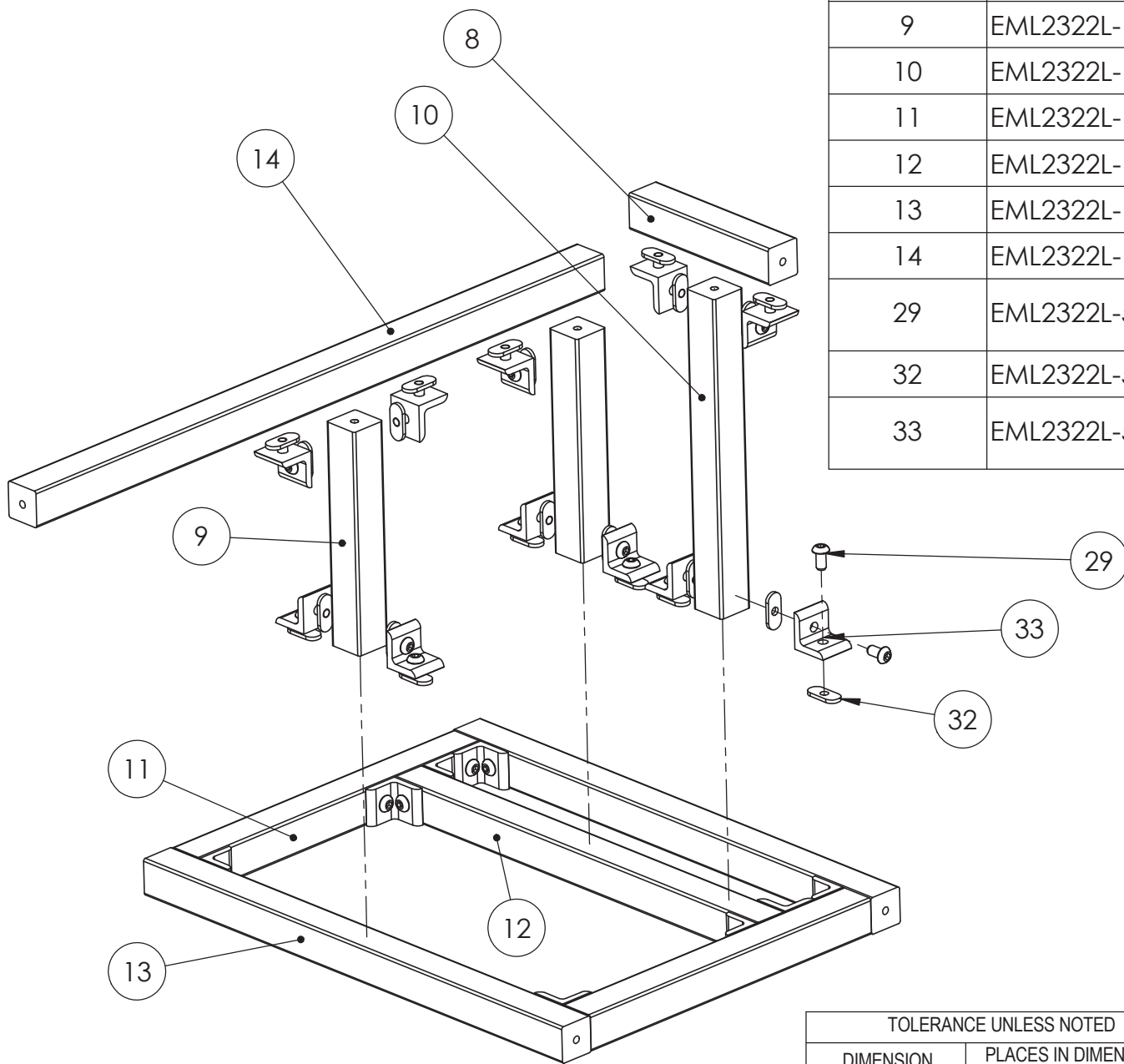

ITEM NO.	PART NUMBER	DESCRIPTION	QTY.
8	EML2322L-121	80/20 Extrusion, 5"	1
9	EML2322L-122	80/20 Extrusion, 6.1"	2
10	EML2322L-123	80/20 Extrusion, 8.8"	1
11	EML2322L-124	80/20 Extrusion, 9.8"	2
12	EML2322L-125	80/20 Extrusion, 13"	1
13	EML2322L-126	80/20 Extrusion, 15"	2
14	EML2322L-127	80/20 Extrusion, 19.8"	1
29	EML2322L-502	0.25-20 button head cap screw	38
32	EML2322L-505	80/20 0.25-20 T-nut	38
33	EML2322L-506	80/20 90 Degree Angle Bracket	19

NOTES:
 1. DIMS IN INCHES
 2. QTY: 1

TITLE:			
Frame Assembly			
DRAWN		DESIGNED	

DIMENSION TYPE	PLACES IN DIMENSION		
	0.0	0.00	0.000
LOCATIONAL	±0.050	±0.020	±0.005
ANGULAR	±5	±2	±0.5

SIZE	DWG. NO.	REV
A	EML2322L-A-120	A
SCALE: 1:4	SHEET 5 OF 5	

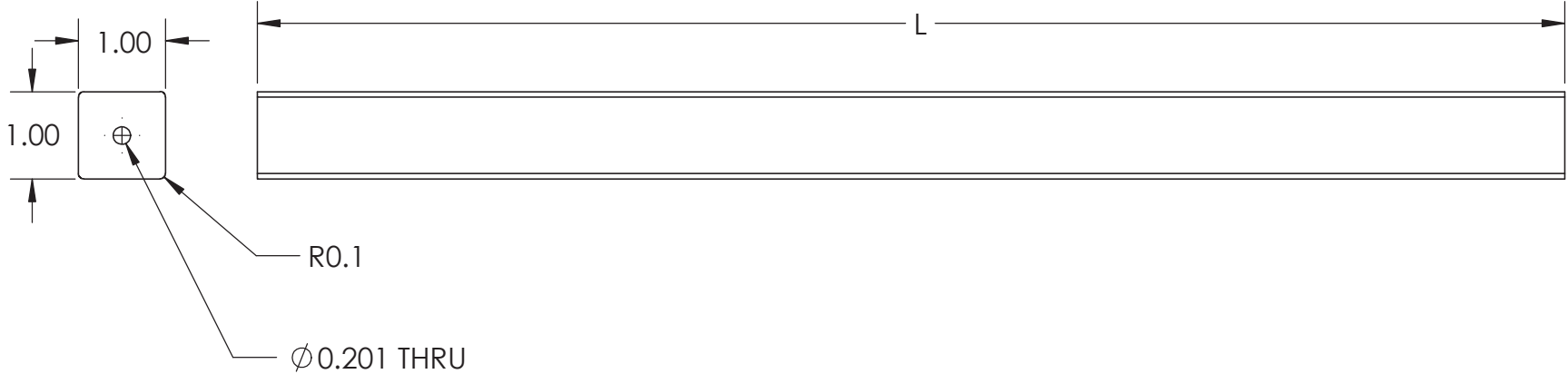
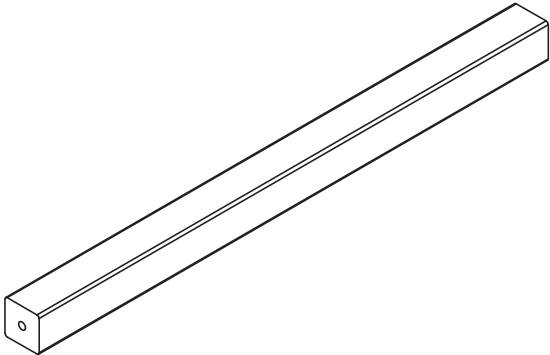

- NOTES:
 1. ALL DIMS IN INCHES
 2. BREAK ALL EDGES
 3. DIM AND MAT'L SPECIFIED BY MANUFACTURER

Length (L)	QTY
5.0	1
6.1	2
8.8	1
9.8	2
13.0	1
15.0	2
19.8	1



TOLERANCE UNLESS NOTED				TITLE:		
MEASURING INSTRUMENT	PLACES IN DIMENSION			80/20 Aluminum Extrusion		
	0.0	0.00	0.000			
CALIPERS	/	/	±0.005	DRAWN	[Redacted]	
PRECISION RULER	/	±0.015	/	DESIGNED		
TAPE MEASURE	±0.050	/	/	SIZE	DWG. NO.	REV
PROTRACTOR	±10	±5	±2	A	EML2322L-121	A
				SCALE: 1 : 2	SHEET 1 OF 1	

5

↑

4

3

2

1

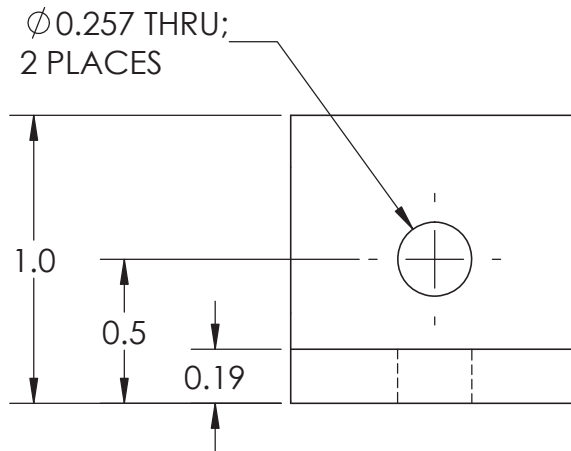
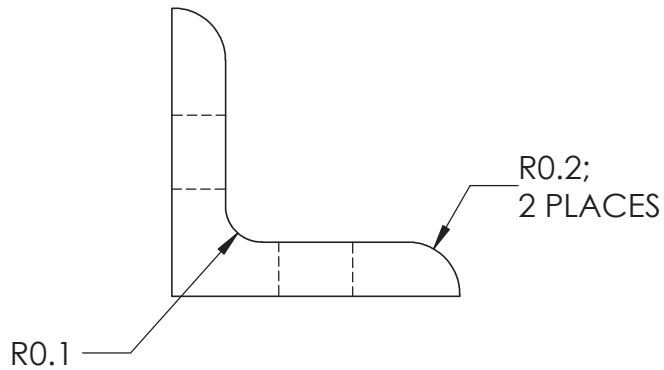
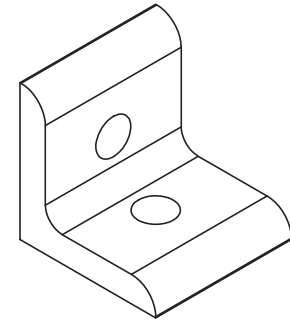
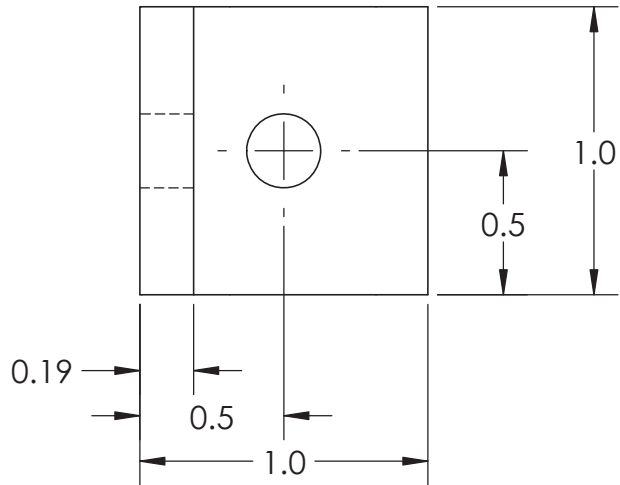

- NOTES:
 1. DIMS IN INCHES
 2. QTY SPECIFIED IN BOM
 3. DIMS SPECIFIED BY MANUFACTURER
 4. MAT'L: ALUMINUM

TOLERANCE UNLESS NOTED				TITLE:		
MEASURING INSTRUMENT	PLACES IN DIMENSION			80/20 90 Degree Angle Bracket		
	0.0	0.00	0.000	DRAWN	J. DERSCH	
CALIPERS	/	/	±0.005	DESIGNED	80/20 INC.	
PRECISION RULER	/	±0.015	/	SIZE	DWG. NO.	REV
TAPE MEASURE	±0.030	/	/	A	EML2322L-506	A
PROTRACTOR	±10	±5	±2	SCALE: 1.5:1		SHEET 1 OF 1

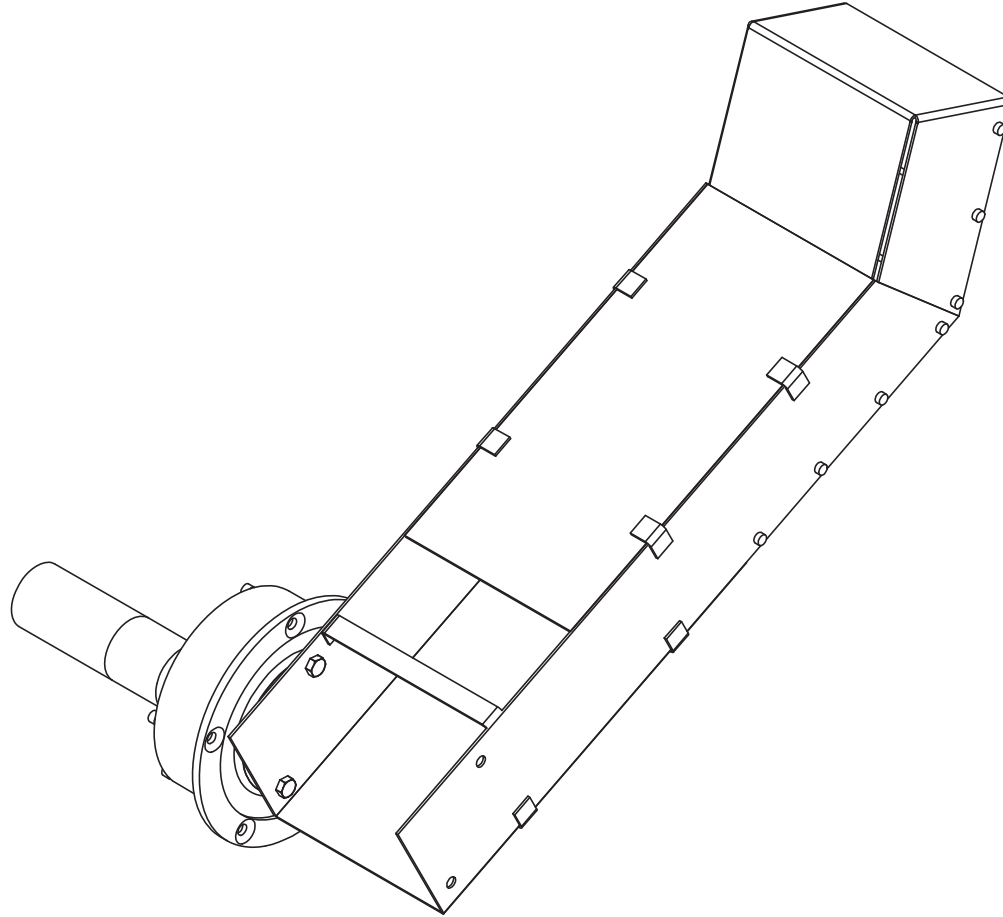

NOTES:
 1. DIMS IN INCHES
 2. QTY: 1

TITLE:				Ball Collector Assembly		
DRAWN				[Redacted]		
DESIGNED				[Redacted]		
SIZE	DWG. NO.		REV			
A	EML2322L-A-200		A			
SCALE: 1:4				SHEET 1 OF 3		

DIMENSION TYPE	PLACES IN DIMENSION		
	0.0	0.00	0.000
LOCATIONAL	±0.050	±0.020	±0.005
ANGULAR	±5	±2	±0.5

TOLERANCE UNLESS NOTED

5



4

3

2

1

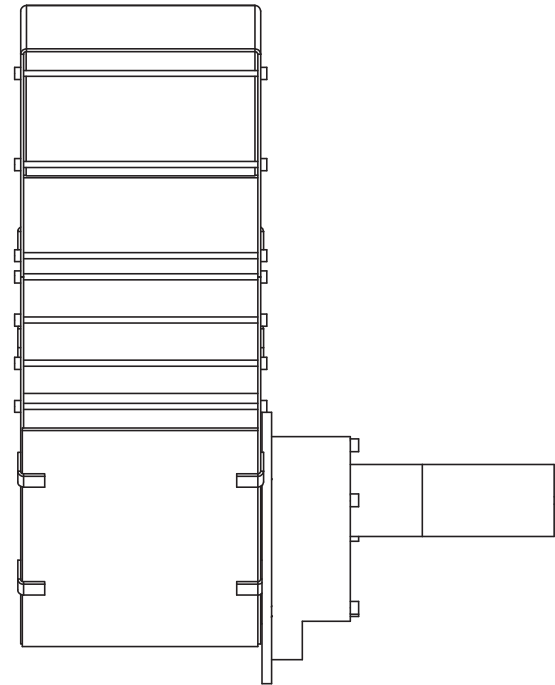
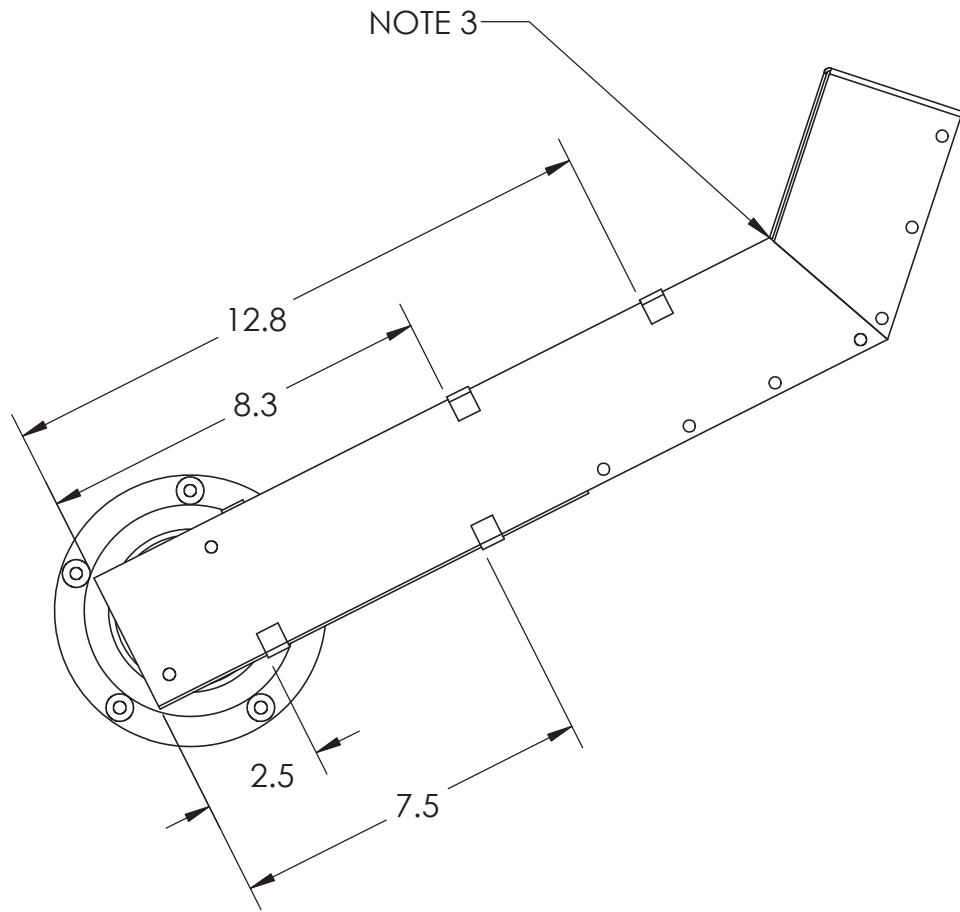

- NOTES:
1. DIMS IN INCHES
 2. QTY: 1
 3. TACK WELD ALL THREE SIDES

TITLE:				Ball Collector Assembly			
DRAWN				[Redacted]			
DESIGNED				[Redacted]			
DIMENSION TYPE		PLACES IN DIMENSION		SIZE	DWG. NO.	REV	
		0.0	0.00	0.000	A	EML2322L-A-200	A
LOCATIONAL		±0.050	±0.020	±0.005			
ANGULAR		±5	±2	±0.5			
SCALE: 1:4				SHEET 2 OF 3			

5

↑

4

3

2

1

ITEM NO.	PART NUMBER	DESCRIPTION	QTY.
15	EML2322L-201	4.5 RPM Globe Gear Motor	1
16	EML2322L-202	Ball Collector Front Box	1
17	EML2322L-203	Ball Collector Rib	1
18	EML2322L-204	Ball Collector Side Panel	2
19	EML2322L-205	Ball Collector Top Panel	2
20A	EML2322L-206A	Rubber Band, Collector	7
21	EML2322L-207	90 degree sheet metal welding tab	8
34	EML2322L-507	M6x1.0 12mm hex cap screw	2

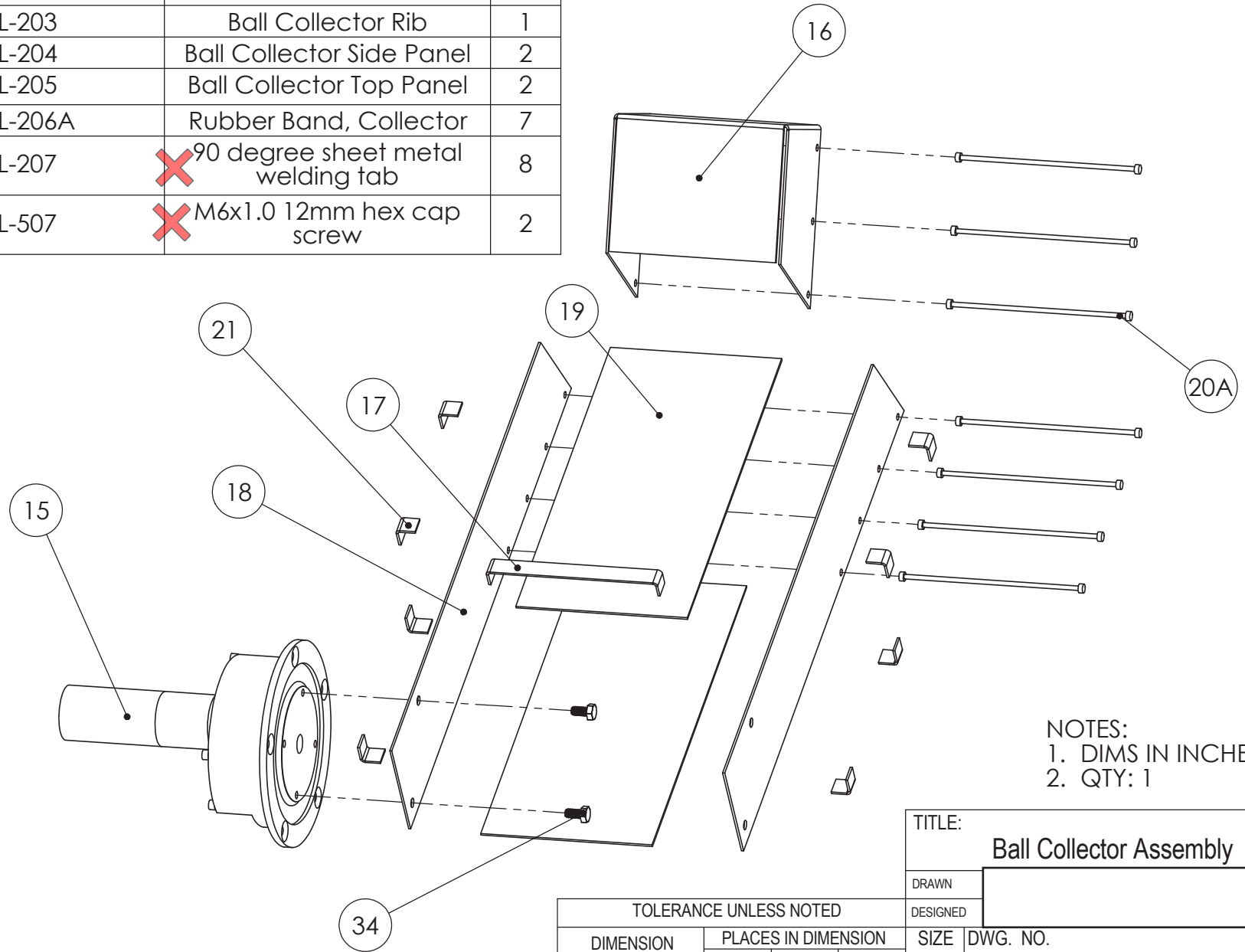

NOTES:
 1. DIMS IN INCHES
 2. QTY: 1

TITLE:			
Ball Collector Assembly			
DRAWN			
DESIGNED			

DIMENSION TYPE	PLACES IN DIMENSION		
	0.0	0.00	0.000
LOCATIONAL	±0.050	±0.020	±0.005
ANGULAR	±5	±2	±0.5

SIZE	DWG. NO.	REV
A	EML2322L-A-200	A
SCALE: 1:4	SHEET 3 OF 3	

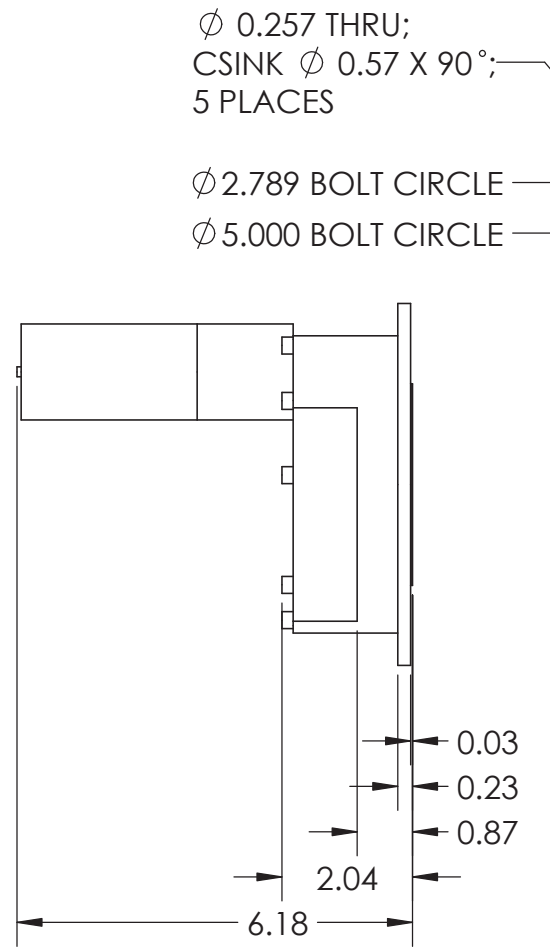
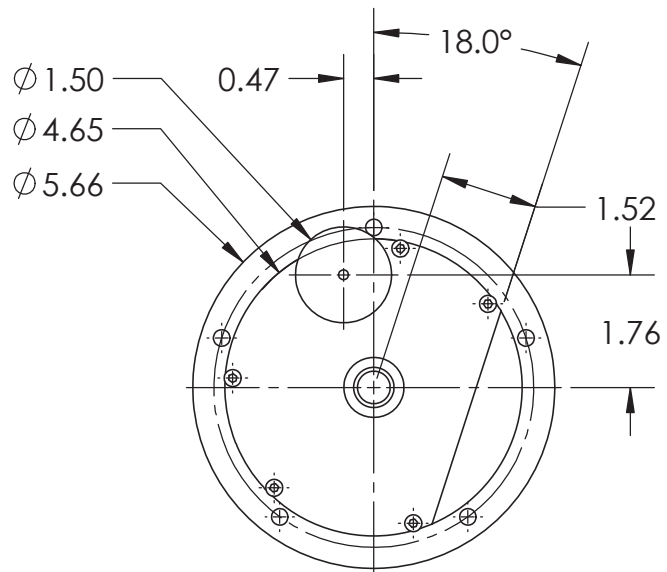

ϕ 0.257 THRU;
 CSINK ϕ 0.57 X 90°;
 5 PLACES
 ϕ 2.789 BOLT CIRCLE
 ϕ 5.000 BOLT CIRCLE

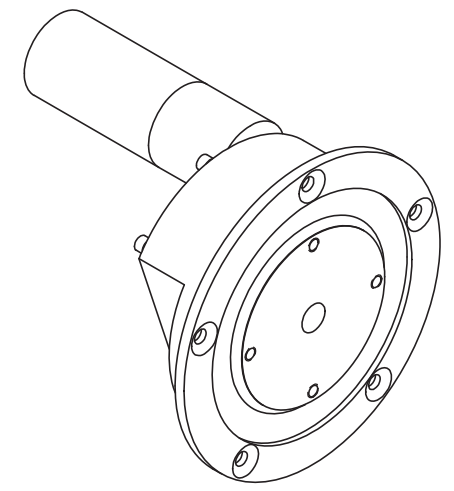
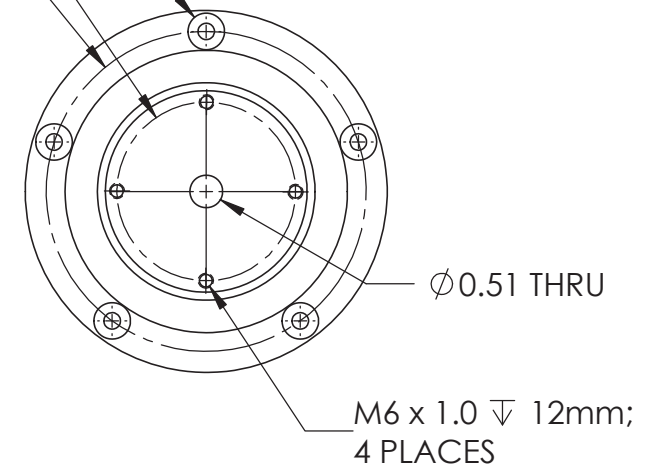

NOTES:
 1. DIMS IN INCHES
 2. QTY SPECIFIED IN BOM
 3. DIMS AND MAT'L SPECIFIED BY MANUFACTURER

TOLERANCE UNLESS NOTED				TITLE:		
MEASURING INSTRUMENT	PLACES IN DIMENSION			4.5 RPM Globe Gear Motor		
	0.0	0.00	0.000	DRAWN	J. DERSCH	
CALIPERS	/	/	±0.005	DESIGNED	GLOBE	
PRECISION RULER	/	±0.015	/	SIZE	DWG. NO.	REV
TAPE MEASURE	±0.030	/	/	A	EML2322L-201	A
PROTRACTOR	±10	±5	±2	SCALE: 1:3		SHEET 1 OF 1

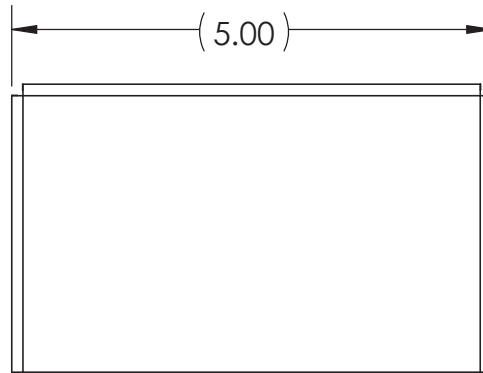
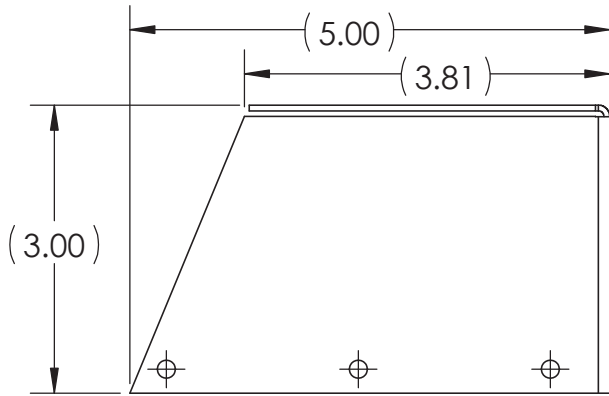
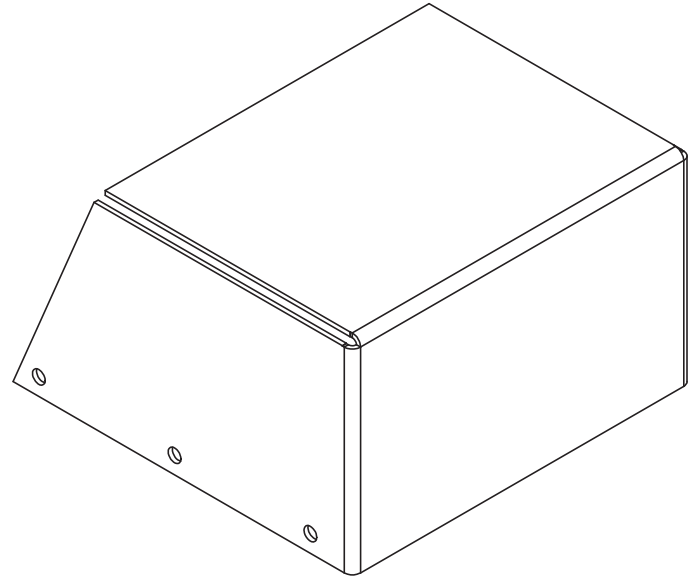
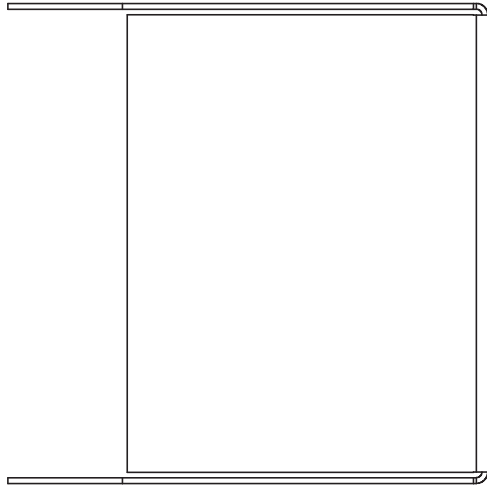

- NOTES:
 1. QTY: 1
 2. ALL DIMS IN INCHES
 3. MATL: 16 GAUGE SHEET STEEL
 4. FINISH NOTED SURFACES
 5. BREAK ALL EDGES

FOLDED VIEW

TOLERANCE UNLESS NOTED				TITLE:		
OPERATION	PLACES IN DIMENSION			Ball Collector Front Box DRAWN: [REDACTED] DESIGNED: [REDACTED]		
	0.0	0.00	0.000			
MACHINING	[Hatched]			SIZE	DWG. NO.	REV
SHEETMETAL (SHEAR, BEND)	±0.1	±0.060	±0.030	A	EML2322L-202	A
WELDING	±0.1	±0.060	[Hatched]	SCALE: 1:2		SHEET 1 OF 2
ANGULAR DIMS	±5	±2	[Hatched]			

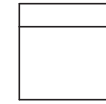
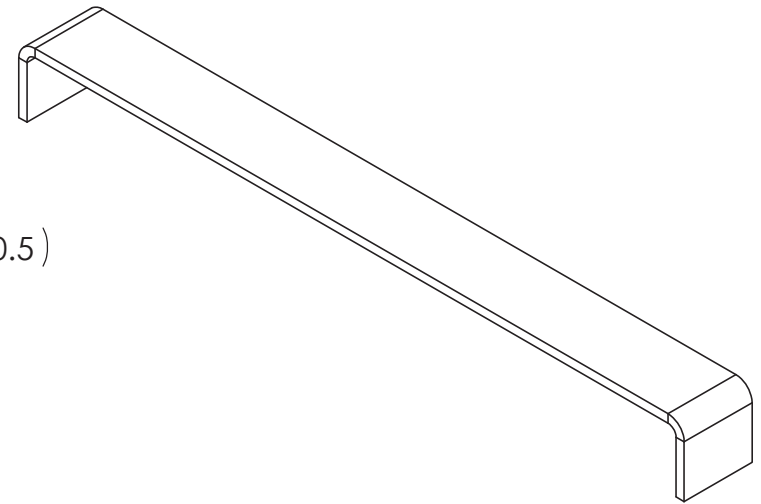
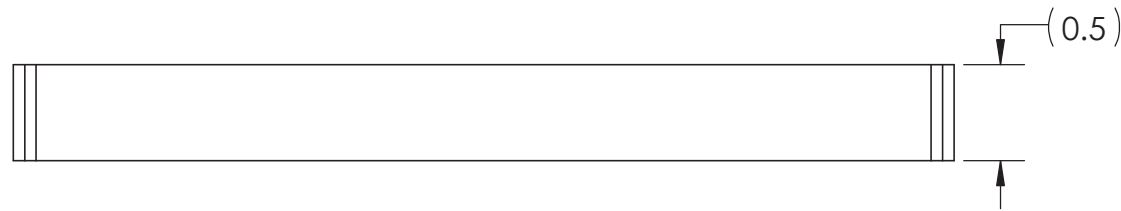
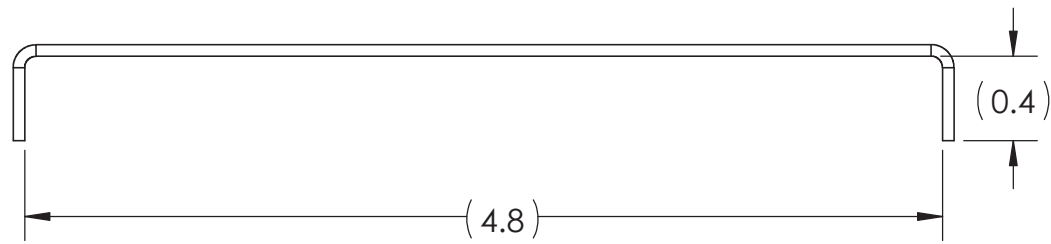

- NOTES:
 1. QTY: 1
 2. ALL DIMS IN INCHES
 3. MATL: 16 GAUGE SHEET STEEL
 4. FINISH NOTED SURFACES
 5. BREAK ALL EDGES

FOLDED VIEW

TOLERANCE UNLESS NOTED				TITLE:		
OPERATION	PLACES IN DIMENSION			Ball Collector Support Rib		
	0.0	0.00	0.000			
MACHINING	//			DRAWN		
SHEETMETAL (SHEAR, BEND)	±0.1	±0.060	±0.030	DESIGNED		
WELDING	±0.1	±0.060	//	SIZE	DWG. NO.	REV
ANGULAR DIMS	±5	±2	//	A	EML2322L-203	A
				SCALE: 1:1		SHEET 1 OF 2

5

↑

4

3

2

1

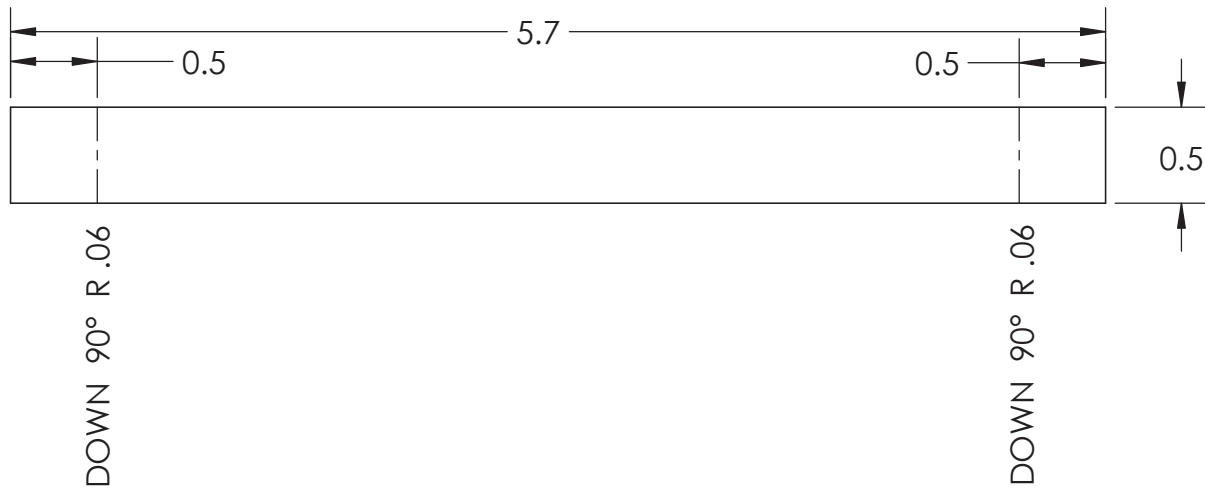

- NOTES:
1. QTY: 1
 2. ALL DIMS IN INCHES
 3. MATL: 16 GAUGE SHEET STEEL
 4. FINISH NOTED SURFACES
 5. BREAK ALL EDGES

UNFOLDED VIEW

TOLERANCE UNLESS NOTED			TITLE: Ball Collector Support Rib		
OPERATION	PLACES IN DIMENSION			DRAWN	DESIGNED
	0.0	0.00	0.000		
MACHINING	//			SIZE	DWG. NO.
SHEETMETAL (SHEAR, BEND)	±0.1	±0.060	±0.030	A	EML2322L-203
WELDING	±0.1	±0.060	//		
ANGULAR DIMS	±5	±2	//	SCALE: 1:1	SHEET 2 OF 2

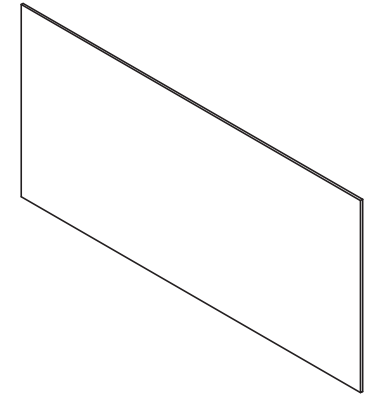

- NOTES:
 1. QTY: 2
 2. ALL DIMS IN INCHES
 3. MATL: 16 GAUGE SHEET STEEL
 4. FINISH NOTED SURFACES
 5. BREAK ALL EDGES

TOLERANCE UNLESS NOTED				TITLE:		
OPERATION	PLACES IN DIMENSION			DRAWN	Ball Collector Top Panel	
	0.0	0.00	0.000			
MACHINING	/ / / / / / / / / /			DESIGNED		
SHEETMETAL (SHEAR, BEND)	±0.1	±0.060	±0.030	SIZE	DWG. NO.	REV
WELDING	±0.1	±0.060	/ / / / / /	A	EML2322L-205	A
ANGULAR DIMS	±5	±2	/ / / / / /	SCALE: 1:2		SHEET 1 OF 1

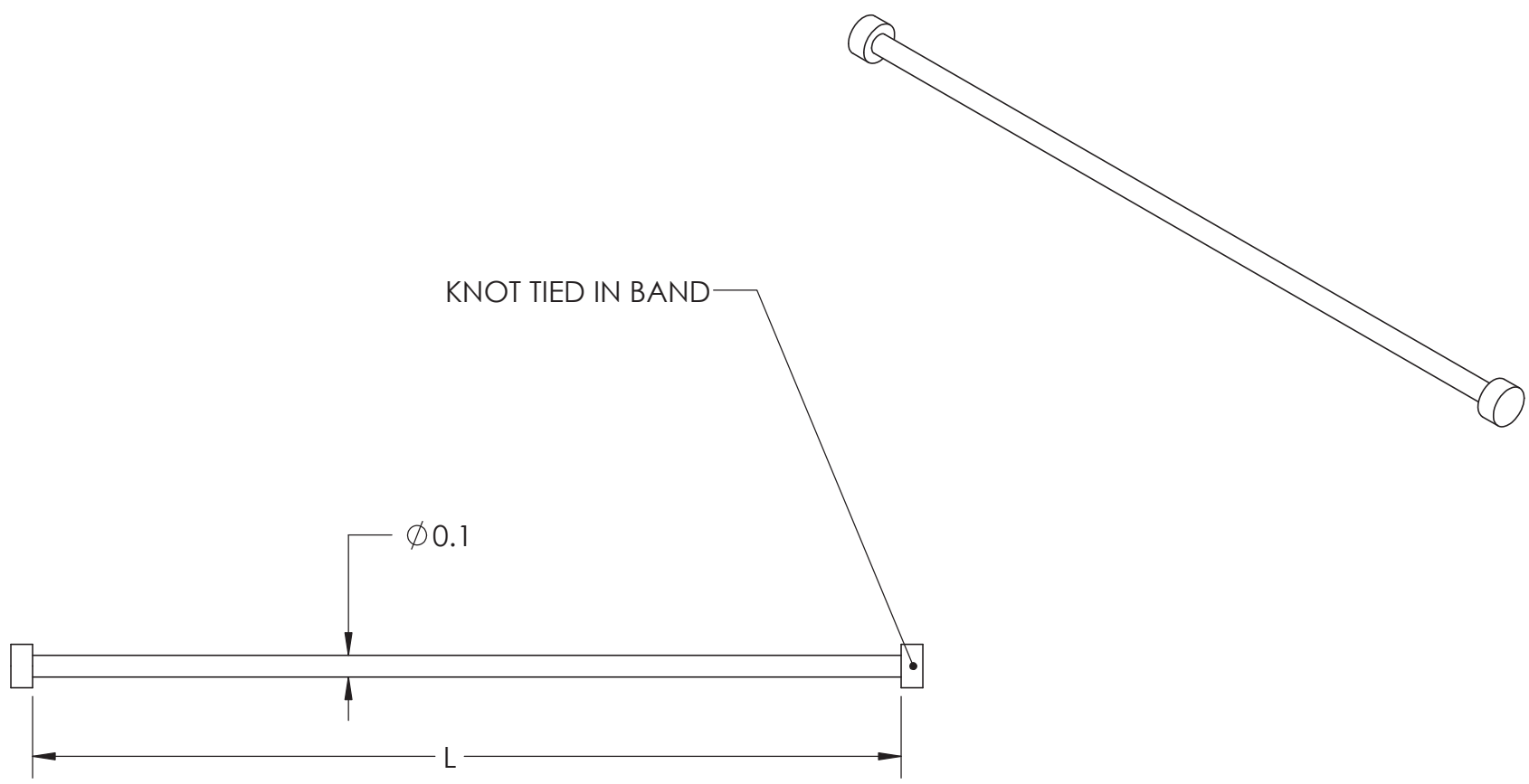

- NOTES:
 1. DIMS IN INCHES
 2. QTY: 8
 3. LENGTH (L) IS VARIABLE
 4. DIA. SHRINKS AS LENGTH INCREASES

ITEM NO.	LENGTH (L)	QTY.
20A	5.0	7
20B	3.1	1

TOLERANCE UNLESS NOTED				TITLE: Rubber Band			
OPERATION	PLACES IN DIMENSION			DRAWN	DWG. NO. EML2322L-206		REV
	0.0	0.00	0.000				
MACHINING	±0.050	±0.020	±0.005	DESIGNED			
CUT OFF (SAW, BURN, SHEAR)	±0.1	±0.060		SIZE			
WELDING	±0.1	±0.060		A			A
ANGULAR DIMS	±5	±2	±0.5	SCALE: 1:1			SHEET 1 OF 1

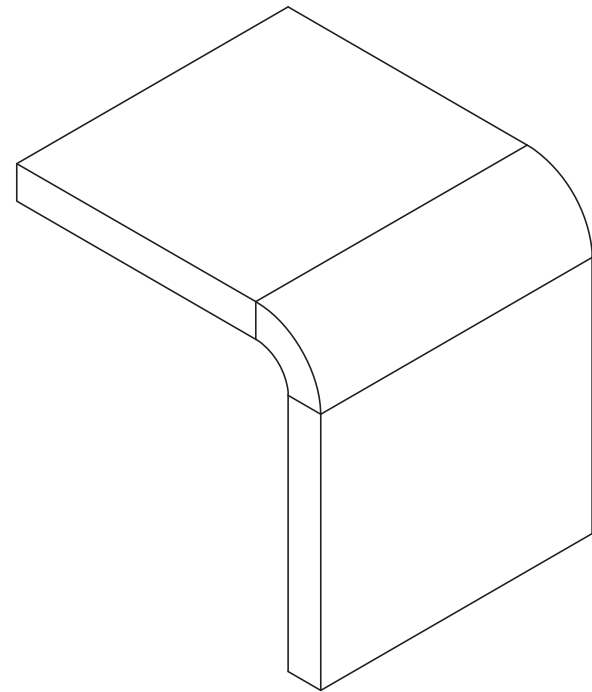
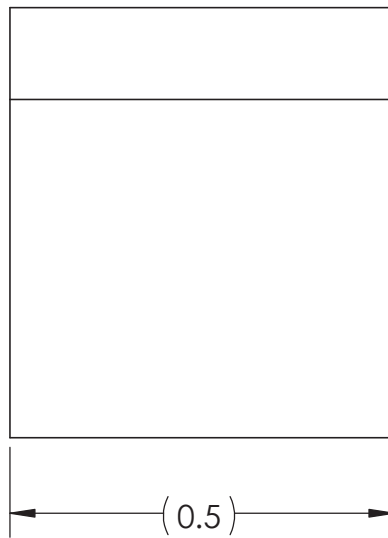
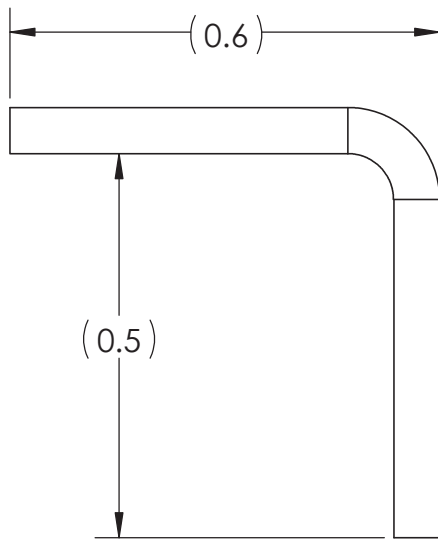

- NOTES:
 1. DIMS IN INCHES
 2. QTY: 11
 3. MAT'L: 16 GA. SHEET STEEL
 4. FINISH NOTED SURFACES
 5. BREAK ALL EDGES

FOLDED VIEW
(IF APPLICABLE)

TOLERANCE UNLESS NOTED				TITLE:		
OPERATION	PLACES IN DIMENSION			90 degree sheet metal welding tab		
	0.0	0.00	0.000	DRAWN		
MACHINING				DESIGNED		
SHEETMETAL (SHEAR, BEND)	±0.1	±0.060	±0.030	SIZE	DWG. NO.	REV
WELDING	±0.1	±0.060		A	EML2322L-207	A
ANGULAR DIMS	±5	±2		SCALE: 4:1		SHEET 1 OF 2

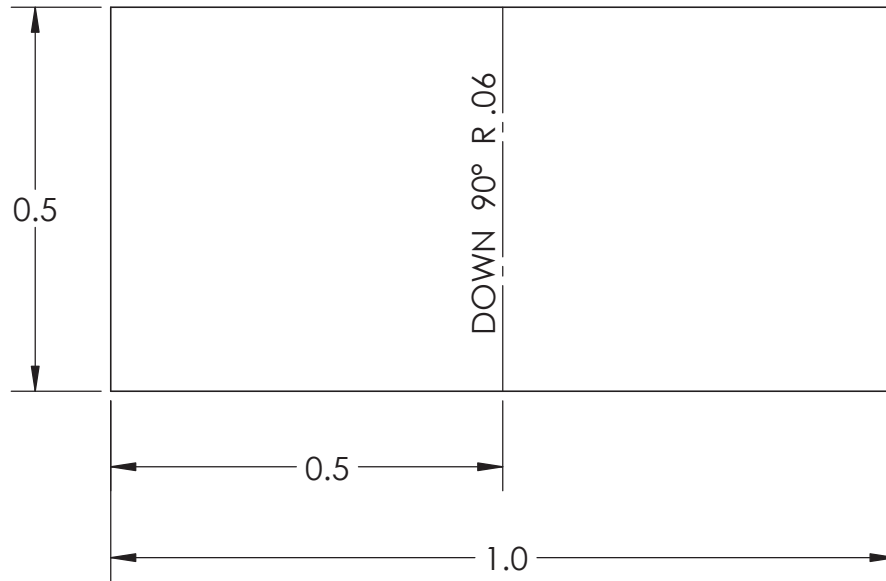

UNFOLDED VIEW
(IF APPLICABLE)

- NOTES:
 1. DIMS IN INCHES
 2. QTY: 11
 3. MAT'L: 16 GA. SHEET STEEL
 4. FINISH NOTED SURFACES
 5. BREAK ALL EDGES

TOLERANCE UNLESS NOTED			TITLE:		
OPERATION	PLACES IN DIMENSION			90 degree sheet metal welding tab	
	0.0	0.00	0.000	DRAWN	
MACHINING	//			DESIGNED	
SHEETMETAL (SHEAR, BEND)	±0.1	±0.060	±0.030	SIZE	DWG. NO.
WELDING	±0.1	±0.060	//	A	EML2322L-207
ANGULAR DIMS	±5	±2	//	SCALE: 4:1	SHEET 2 OF 2
					REV
					A

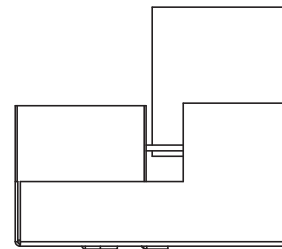
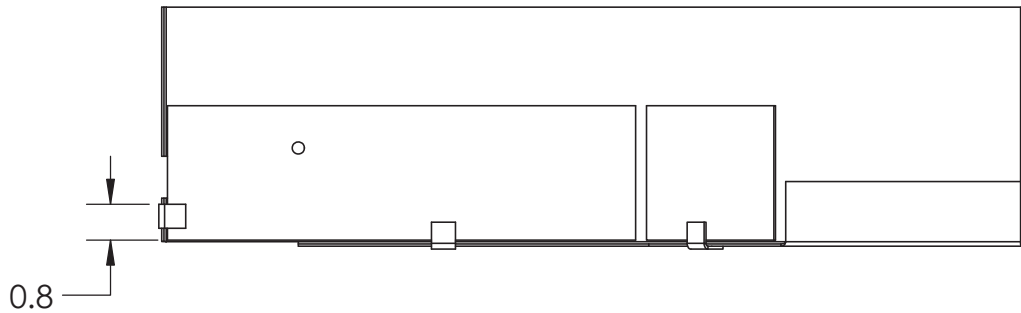
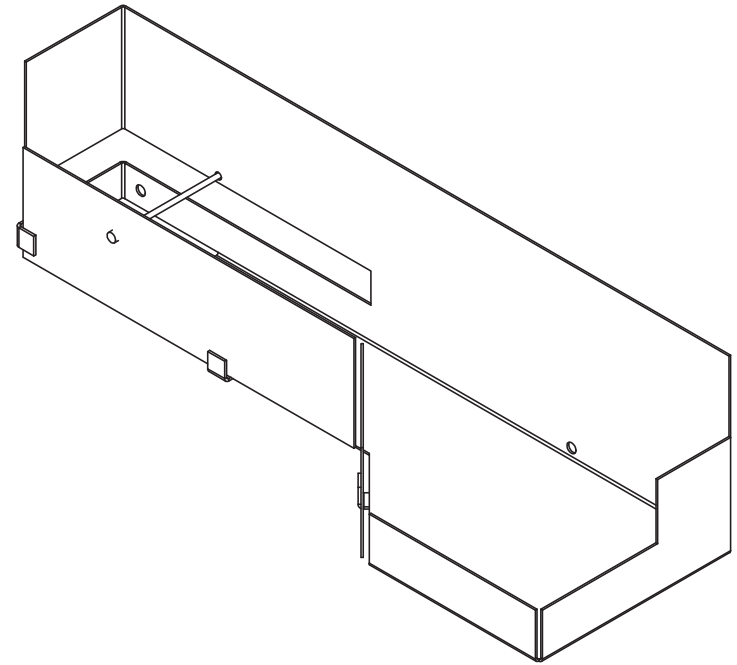
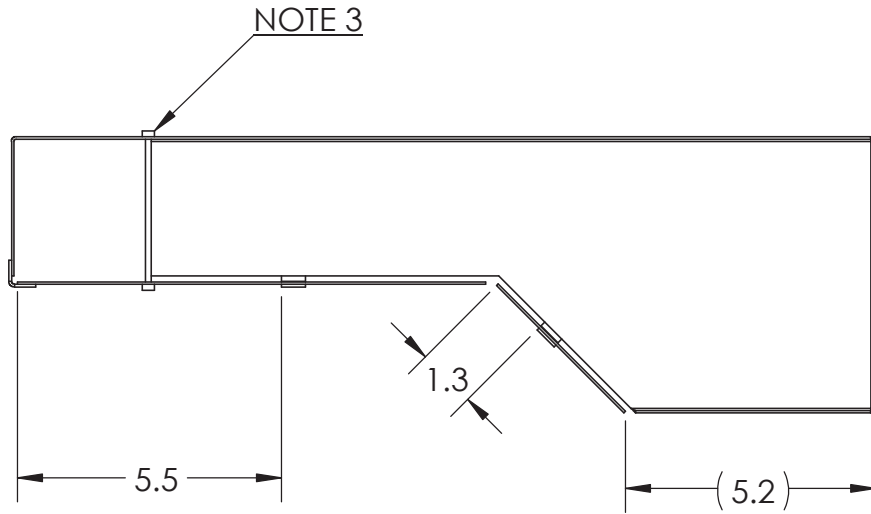

- NOTES:
 1. DIM IN INCHES
 2. QTY: 1
 3. KNOTS TIED IN ELASTIC BAND

TITLE:				Hopper Assembly		
DRAWN				[Redacted]		
DESIGNED				[Redacted]		
DIMENSION TYPE		PLACES IN DIMENSION		SIZE	DWG. NO.	REV
		0.0	0.00	A	EML2322L-A-300	A
LOCATIONAL		±0.050	±0.020			
ANGULAR		±5	±2			
				SCALE: 1:4	SHEET 1 OF 2	

TOLERANCE UNLESS NOTED			
DIMENSION TYPE	PLACES IN DIMENSION		
	0.0	0.00	0.000
LOCATIONAL	±0.050	±0.020	±0.005
ANGULAR	±5	±2	±0.5

5

↑

4

3

2

1

ITEM NO.	PART NUMBER	PART/ASSEMBLY NAME	QTY.
20B	EML2322L-206B	Rubber Band, Hopper	1
21	EML2322L-207	90 Deg Bracket Sheet Metal Welding	3
22	EML2322L-301	Ball Hopper Main Body	1
23	EML2322L-302	Ball Hopper Side Pannel	1
24	EML2322L-303	Ball Hopper Angled Panel	1

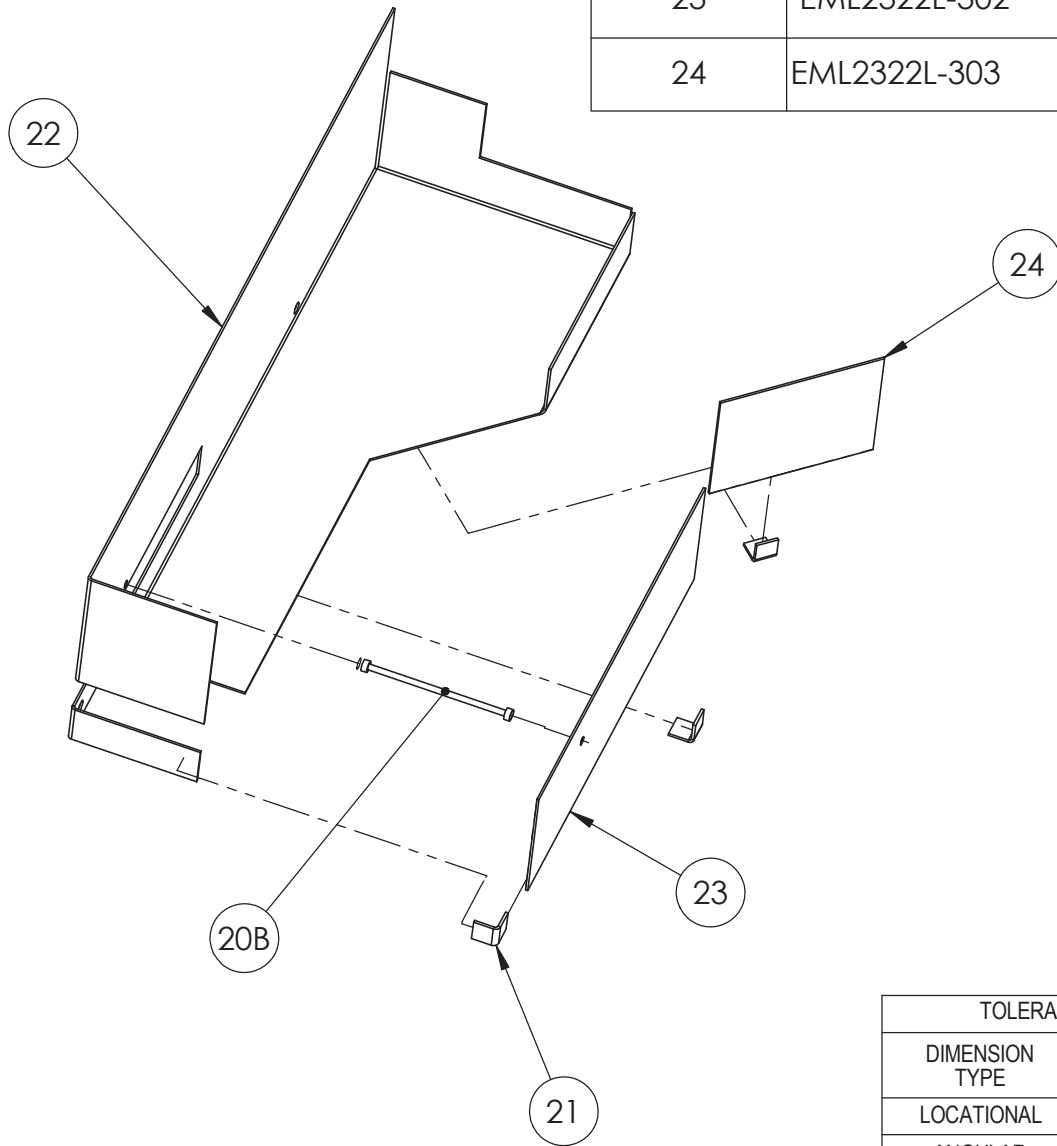

NOTES:
 1. DIM IN INCHES
 2. QTY: 1

TITLE:				Hopper Assembly		
DRAWN				[Redacted]		
DESIGNED				[Redacted]		
DIMENSION TYPE		PLACES IN DIMENSION		SIZE	DWG. NO.	REV
		0.0	0.00	A	EML2322L-A-300	A
LOCATIONAL		±0.050	±0.020			
ANGULAR		±5	±2			
				SCALE: 1:4	SHEET 2 OF 2	

TOLERANCE UNLESS NOTED			
DIMENSION TYPE	PLACES IN DIMENSION		
	0.0	0.00	0.000
LOCATIONAL	±0.050	±0.020	±0.005
ANGULAR	±5	±2	±0.5

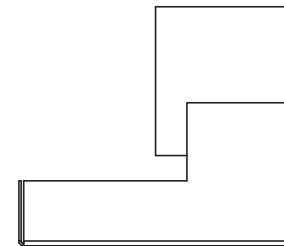
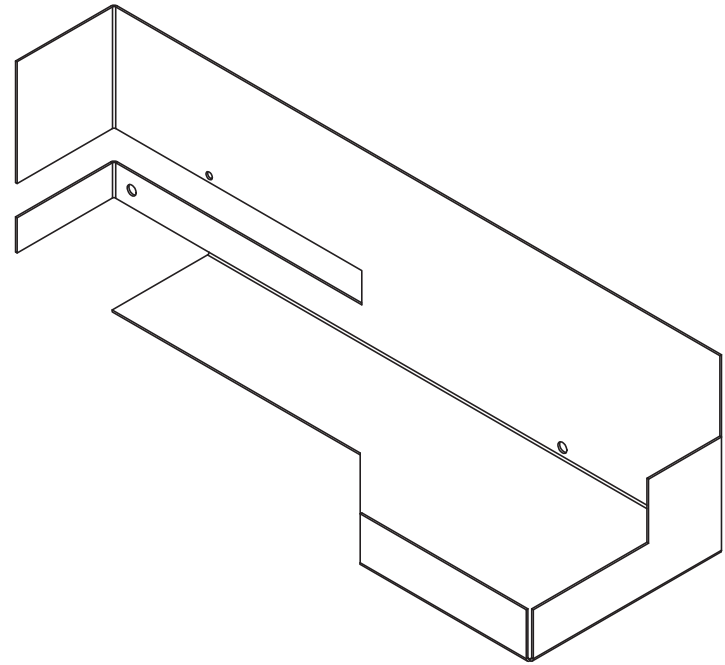
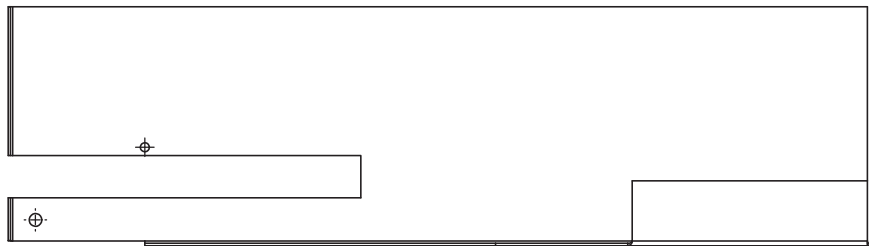
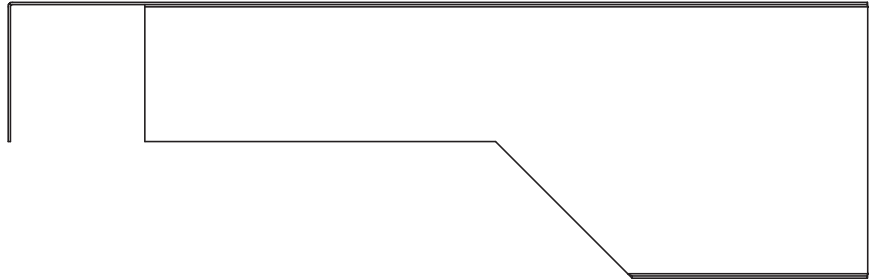

- NOTES:
 1. DIMS IN INCHES
 2. QTY: 1
 3. MAT'L: 18 GA. SHEET STEEL
 4. FINISH NOTED SURFACES
 5. BREAK ALL EDGES

FOLDED VIEW
(IF APPLICABLE)

TOLERANCE UNLESS NOTED				TITLE:		
OPERATION	PLACES IN DIMENSION			DRAWN	Hopper Main Body	
	0.0	0.00	0.000			
MACHINING	//			DESIGNED		
SHEETMETAL (SHEAR, BEND)	±0.1	±0.060	±0.030	SIZE	DWG. NO.	REV
WELDING	±0.1	±0.060	//	A	EML2322L-301	A
ANGULAR DIMS	±5	±2	//	SCALE: 1:4		SHEET 1 OF 3

5

↑

4

3

2

1

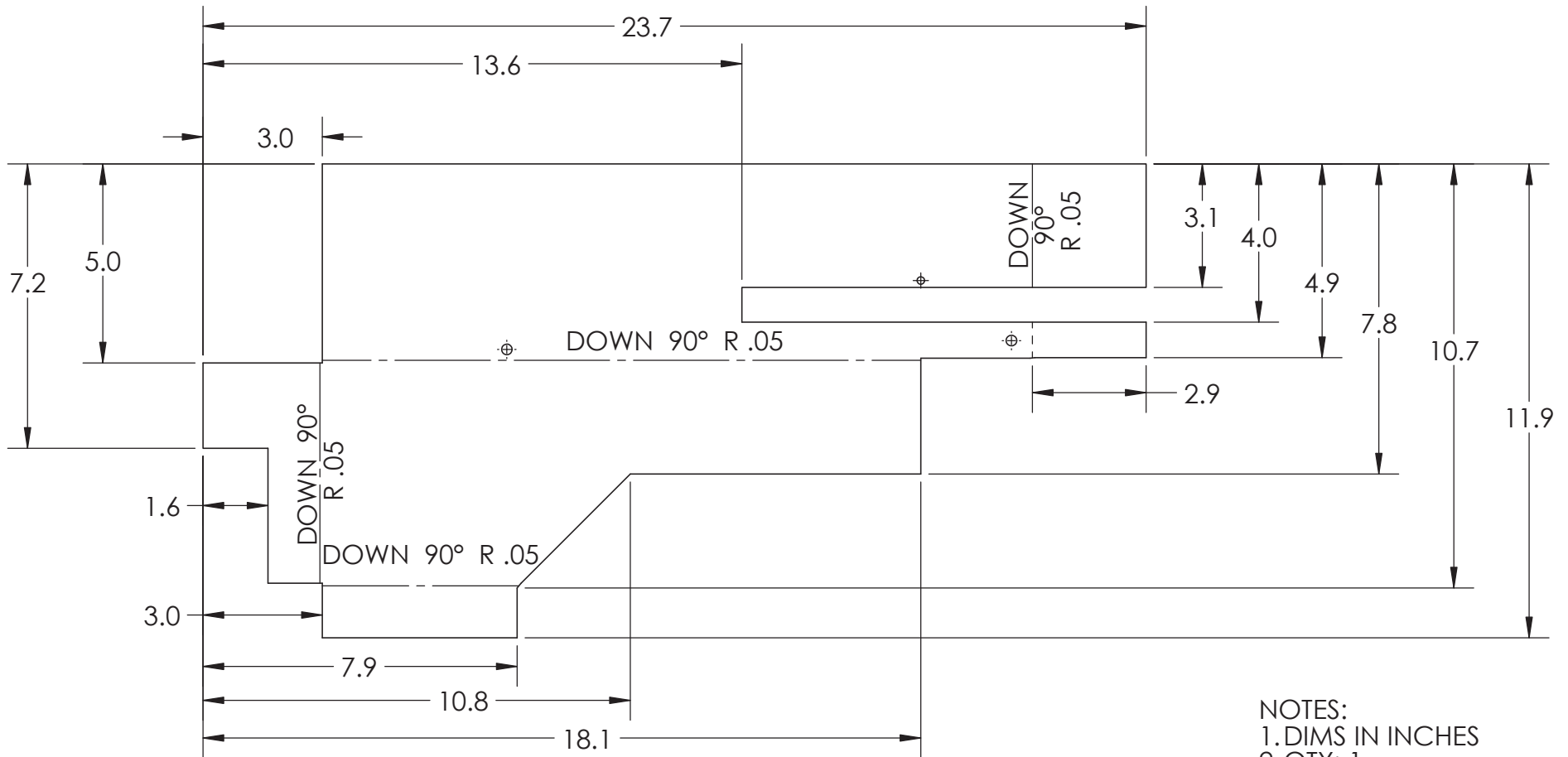

- NOTES:
 1. DIMS IN INCHES
 2. QTY: 1
 3. MAT'L: 18 GA. SHEET STEEL
 4. FINISH NOTED SURFACES
 5. BREAK ALL EDGES

UNFOLDED VIEW
(IF APPLICABLE)

TOLERANCE UNLESS NOTED			TITLE:		
OPERATION	PLACES IN DIMENSION			Hopper Main Body	
	0.0	0.00	0.000	DRAWN	
MACHINING				DESIGNED	
SHEETMETAL (SHEAR, BEND)	±0.1	±0.060	±0.030	SIZE	REV
WELDING	±0.1	±0.060		DWG. NO.	EML2322L-301
ANGULAR DIMS	±5	±2		SCALE: 1:4	SHEET 2 OF 3

5

↑

4

3

2

1

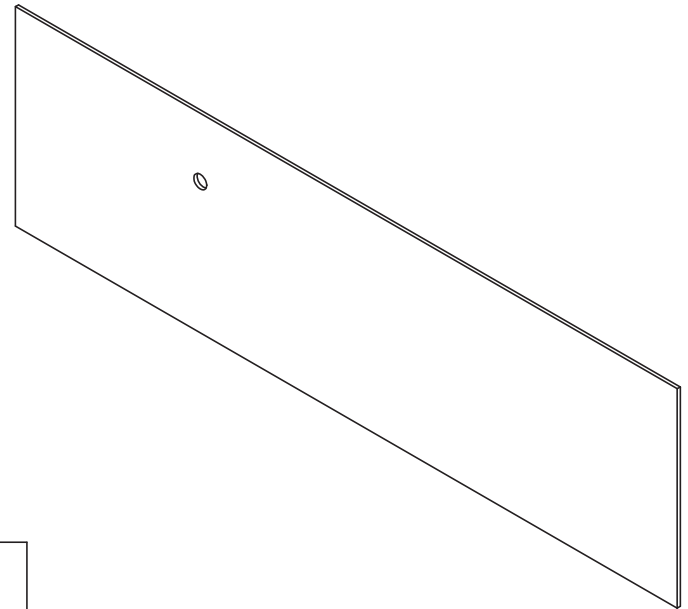
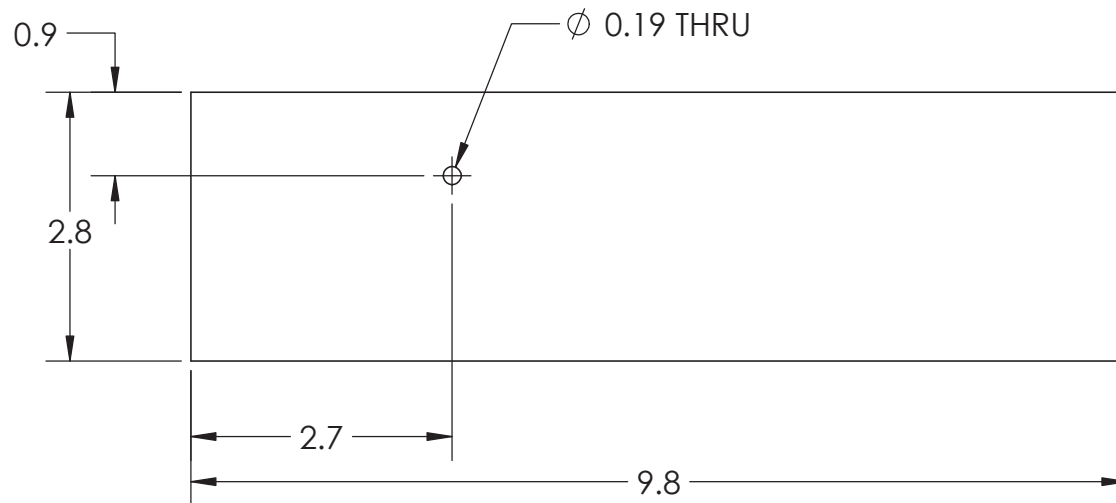

- NOTES:
1. QTY: 1
 2. ALL DIMS IN INCHES
 3. MATL: 18 GAUGE SHEET STEEL
 4. FINISH NOTED SURFACE(S)
 5. BREAK ALL EDGES

TOLERANCE UNLESS NOTED				TITLE:		
OPERATION	PLACES IN DIMENSION			DRAWN		
	0.0	0.00	0.000			
MACHINING	/ / / / / / / / / / / / / / / /			DESIGNED		
SHEETMETAL (SHEAR, BEND)	±0.1	±0.060	±0.030	SIZE	DWG. NO.	REV
WELDING	±0.1	±0.060	/ / / / / / / / / / / /	A	EML2322L-302	A
ANGULAR DIMS	±5	±2	/ / / / / / / / / / / /	SCALE: 1:2		SHEET 1 OF 1

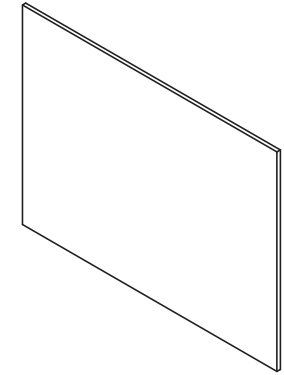
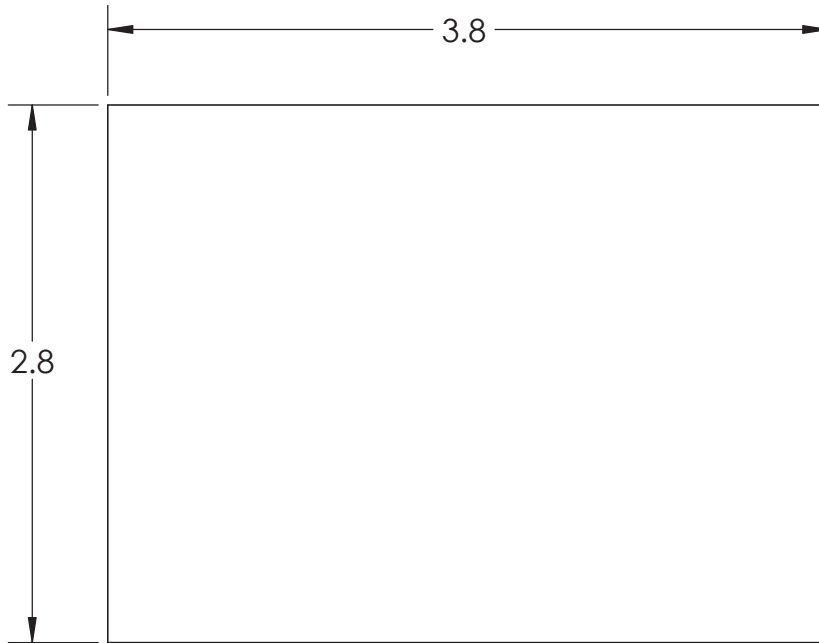

- NOTES:
 1. QTY: 1
 2. ALL DIMS IN INCHES
 3. MATL: 18 GAUGE SHEET STEEL
 4. FINISH NOTED SURFACES
 5. BREAK ALL EDGES

TOLERANCE UNLESS NOTED				TITLE:		
OPERATION	PLACES IN DIMENSION			Hopper Angled Panel		
	0.0	0.00	0.000	DRAWN	[Redacted]	
MACHINING	[Hatched]			DESIGNED	[Redacted]	
SHEETMETAL (SHEAR, BEND)	±0.1	±0.060	±0.030	SIZE	DWG. NO.	REV
WELDING	±0.1	±0.060	[Hatched]	A	EML2322L-303	A
ANGULAR DIMS	±5	±2	[Hatched]	SCALE: 1:1	[Redacted]	SHEET 1 OF 1

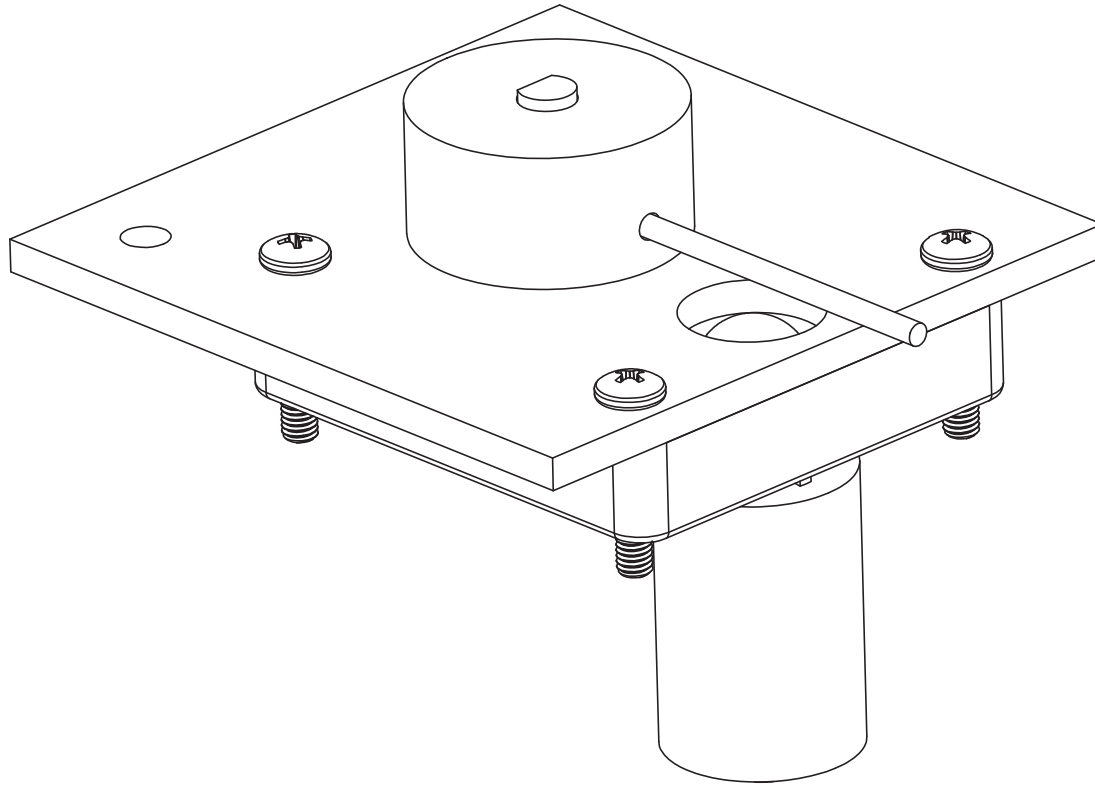

NOTES:
 1. DIMS IN INCHES
 2. QTY: 1

TITLE:		Ball Dispenser Assembly	
DRAWN	[Redacted]		
DESIGNED	[Redacted]		
SIZE	DWG. NO.	REV	
A	EML2322L-A-400	A	
SCALE: 1:1		SHEET 1 OF 3	

DIMENSION TYPE	PLACES IN DIMENSION		
	0.0	0.00	0.000
LOCATIONAL	±0.050	±0.020	±0.005
ANGULAR	±5	±2	±0.5

5



4

3

2

1

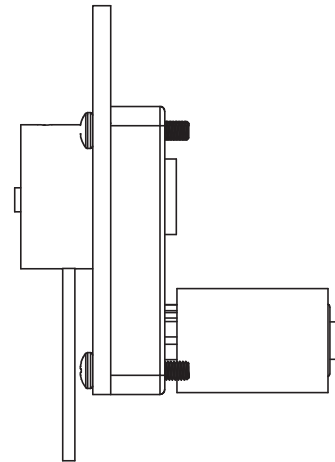
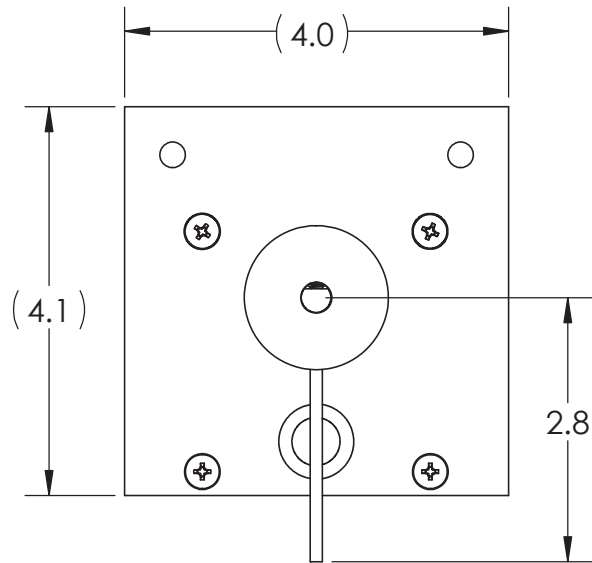
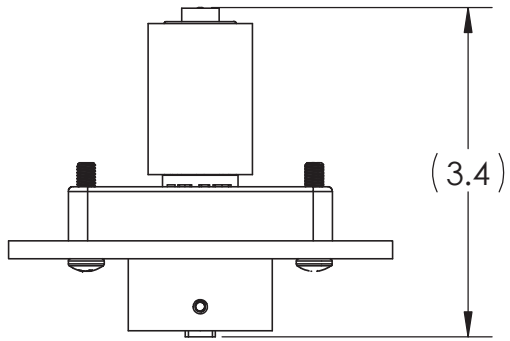

NOTES:
 1. DIMS IN INCHES
 2. QTY: 1

TITLE:		Ball Dispenser Assembly	
DRAWN	[Redacted]		
DESIGNED	[Redacted]		

TOLERANCE UNLESS NOTED				SIZE	DWG. NO.	REV
DIMENSION TYPE	PLACES IN DIMENSION					
	0.0	0.00	0.000	A	EML2322L-A-400	A
LOCATIONAL	±0.050	±0.020	±0.005			
ANGULAR	±5	±2	±0.5			

SCALE: 1:2		SHEET 2 OF 3
------------	--	--------------

ITEM NO.	PART NUMBER	ASSEMBLY/PART NAME	QTY.
25	EML2322L-401	17.5 RPM Molon Gear Motor	1
26	EML2322L-402	Molon Motor Hub	1
27	EML2322L-403	Molon Motor Mount	1
31	EML2322L-504	X 10-32 1 inch phillips machine screw	4
37	EML2322L-510	X 10-24 3/8 inch socket set screw	1
38	EML2322L-511	X 10-24 2.5 inch threaded rod	1

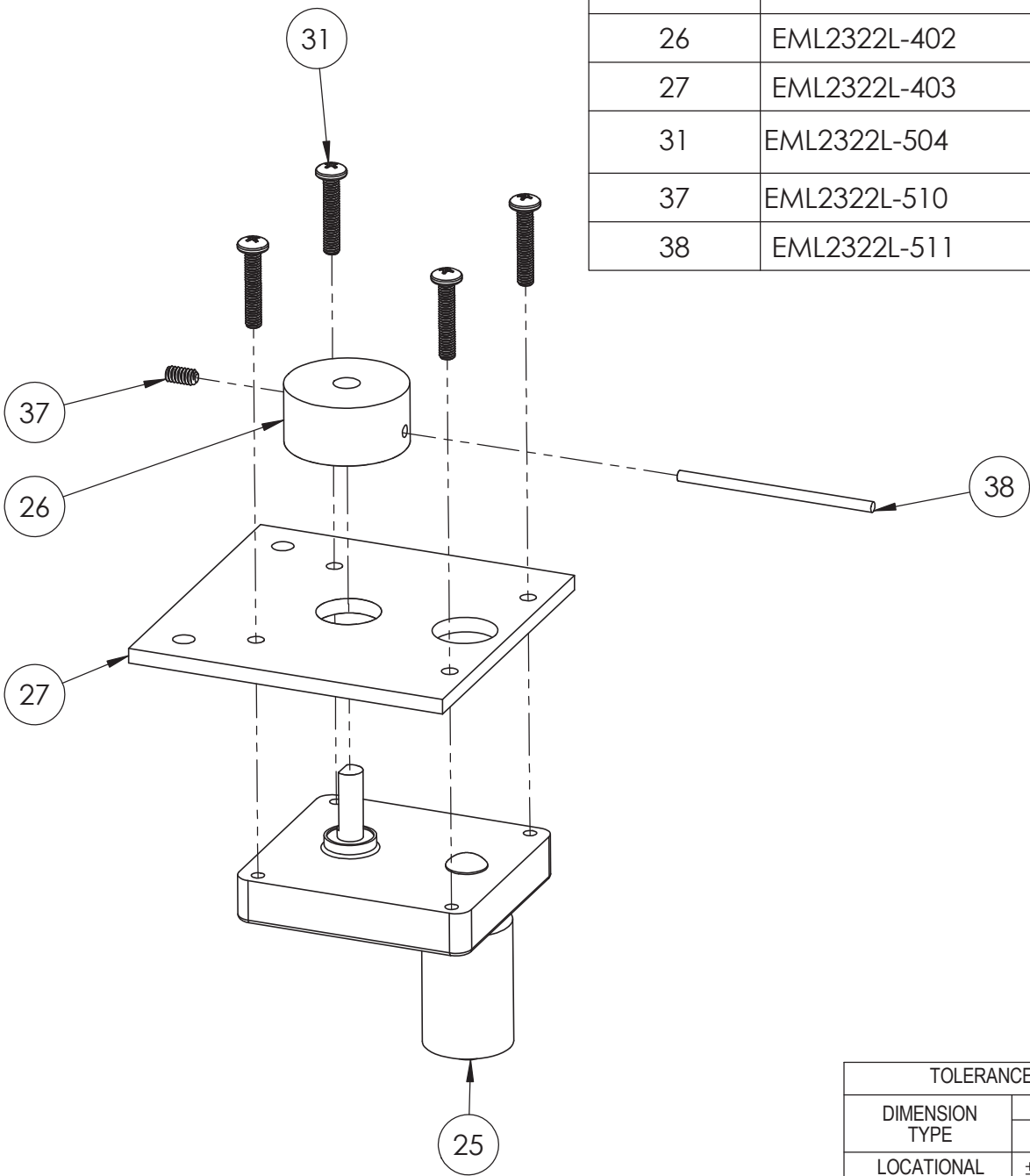

NOTES:
 1. DIMS IN INCHES
 2. QTY: 1

TITLE: Ball Dispenser Assembly

DRAWN: [Redacted]
 DESIGNED: [Redacted]

TOLERANCE UNLESS NOTED				SIZE	DWG. NO.	REV
DIMENSION TYPE	PLACES IN DIMENSION					
	0.0	0.00	0.000	A	EML2322L-A-400	A
LOCATIONAL	±0.050	±0.020	±0.005			
ANGULAR	±5	±2	±0.5			

SCALE: 1:2 SHEET 3 OF 3

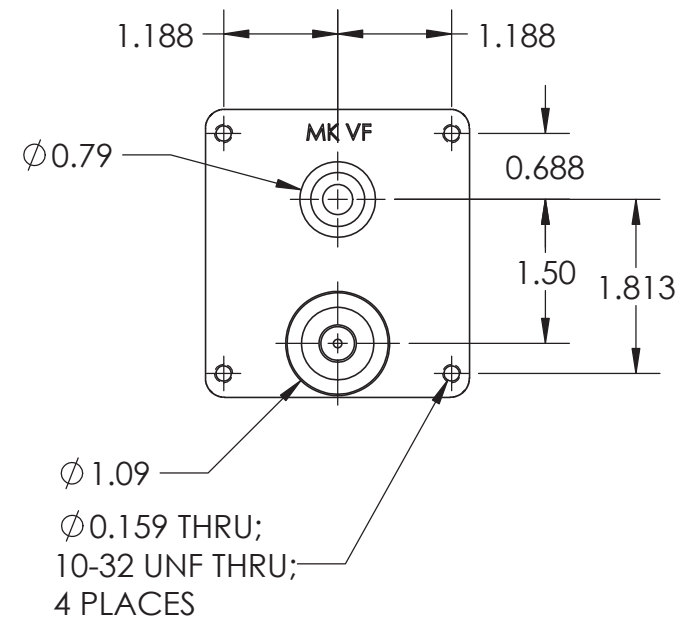
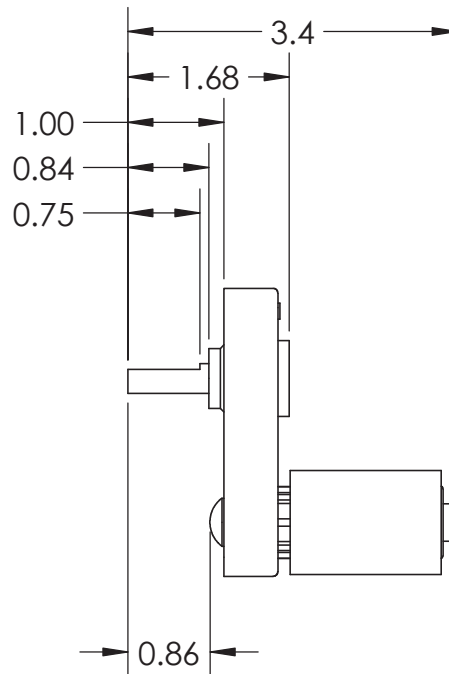
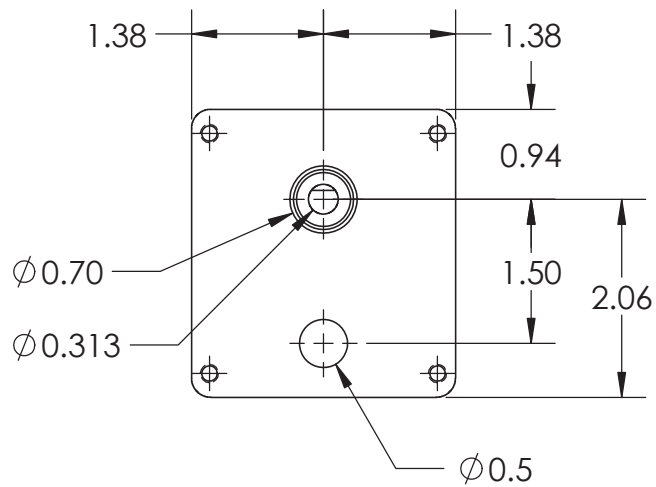
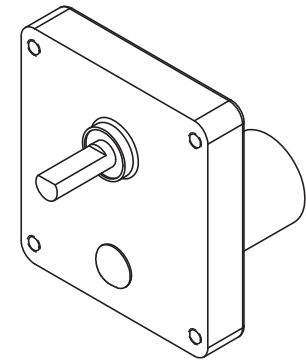

- NOTES:
 1. DIMS IN INCHES
 2. QTY SPECIFIED IN BOM
 3. DIMS AND MAT'L SPECIFIED BY MANUFACTURER

TOLERANCE UNLESS NOTED				TITLE:		
MEASURING INSTRUMENT	PLACES IN DIMENSION			17.5 RPM Molon Gear Motor		
	0.0	0.00	0.000	DRAWN	J. DERSCH	
CALIPERS	/	/	± 0.005	DESIGNED	MOLON	
PRECISION RULER	/	± 0.015	/	SIZE	DWG. NO.	REV
TAPE MEASURE	± 0.030	/	/	A	EML2322L-401	A
PROTRACTOR	± 10	± 5	± 2	SCALE: 1:2		SHEET 1 OF 1

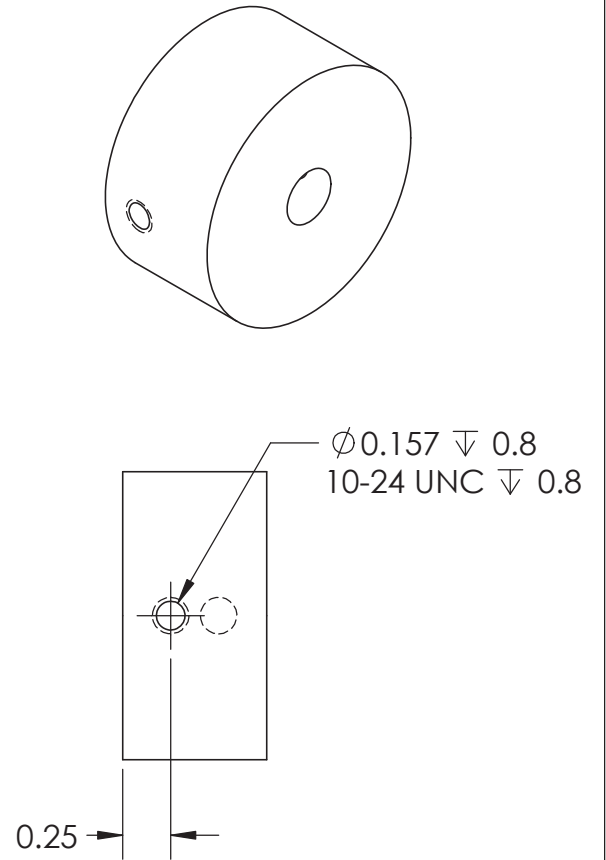
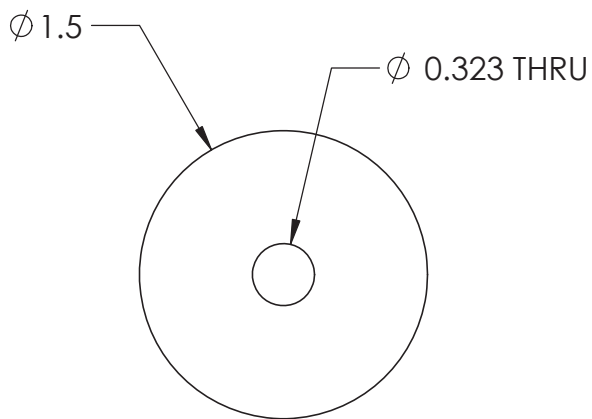
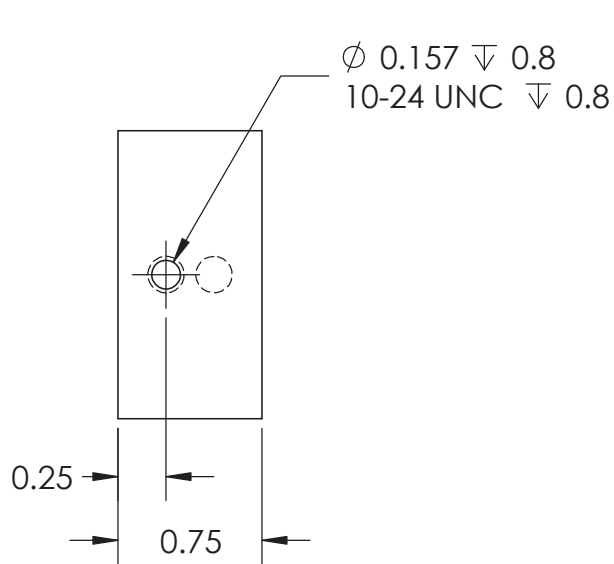

- NOTES:
1. QTY: 1
 2. ALL DIMS IN INCHES
 3. MATL: ALUMINUM
 4. FINISH NOTED SURFACE(S)
 5. BREAK ALL EDGES

TOLERANCE UNLESS NOTED				TITLE:		
OPERATION	PLACES IN DIMENSION			DRAWN		
	0.0	0.00	0.000			
MACHINING	± 0.050	± 0.020	± 0.005	DESIGNED		
CUT OFF (SAW, BURN, SHEAR)	± 0.1	± 0.060		SIZE	DWG. NO.	REV
WELDING	± 0.1	± 0.060		A	EML2322L-402	A
ANGULAR DIMS	± 5	± 2	± 0.5	SCALE: 1:1		SHEET 1 OF 1

Molon Motor Hub

A

EML2322L-402

A

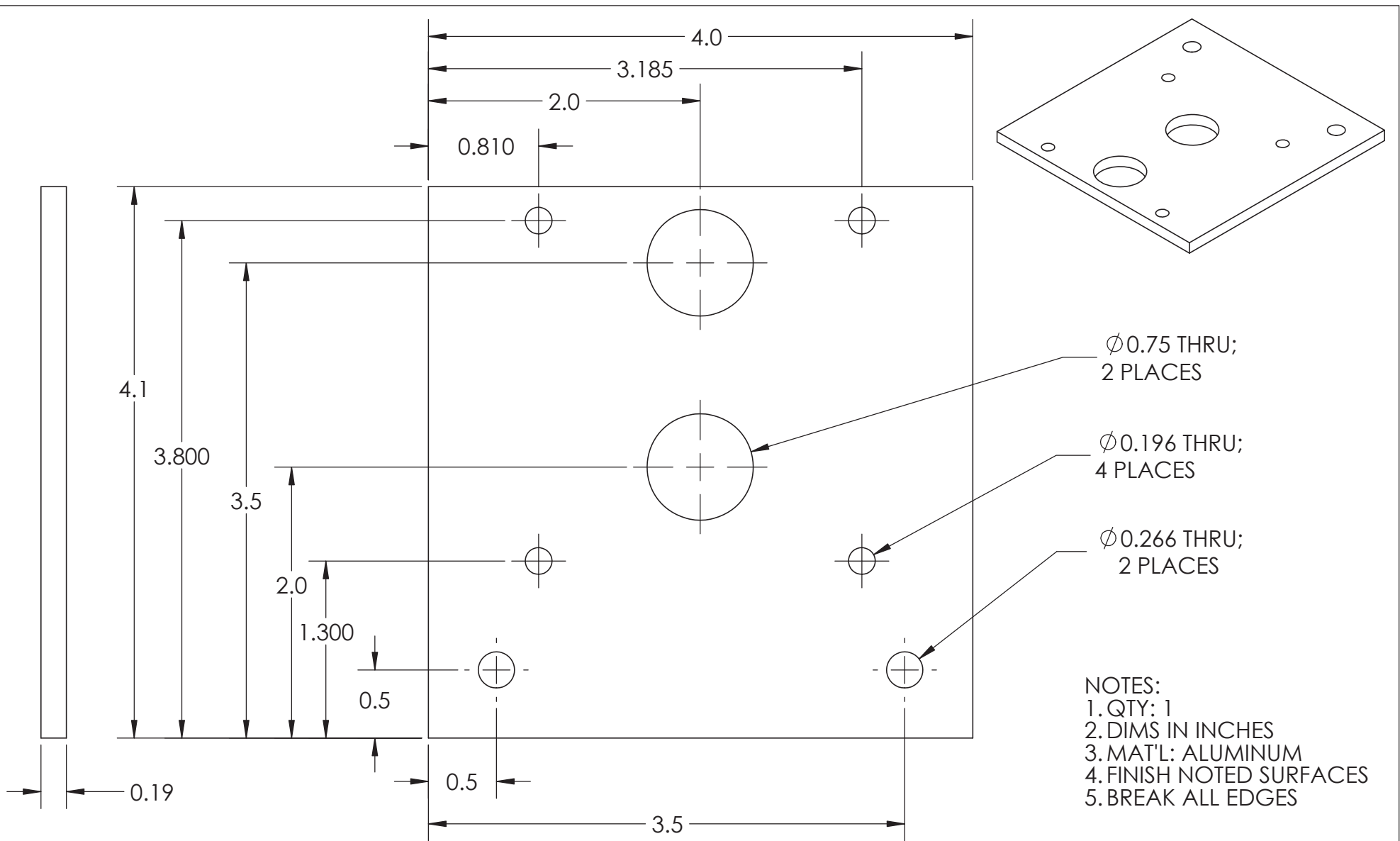

NOTES:
 1. QTY: 1
 2. DIMS IN INCHES
 3. MAT'L: ALUMINUM
 4. FINISH NOTED SURFACES
 5. BREAK ALL EDGES

TOLERANCE UNLESS NOTED			TITLE:			
OPERATION	PLACES IN DIMENSION			Molon Motor Mount		
	0.0	0.00	0.000	DRAWN		
MACHINING	± 0.050	± 0.020	± 0.005	DESIGNED		
CUT OFF (SAW, BURN, SHEAR)	± 0.1	± 0.060		SIZE	DWG. NO.	REV
WELDING	± 0.1	± 0.060		A	EML2322L-403	A
ANGULAR DIMS	± 5	± 2	± 0.5	SCALE: 1:1		SHEET 1 OF 1