

NOTES:
 1. DIMS IN INCHES
 2. QUANTITY 1

TITLE:		Mobile Platform Assembly		
DRAWN		S. MASCIELLO		
DESIGNED		M. BRADDOCK		
SIZE	DWG. NO.	REV		
A	EML2322L-A-MP	A		
SCALE: 1:3	SHEET 1 OF 3			

DIMENSION TYPE	PLACES IN DIMENSION		
	0.0	0.00	0.000
LOCATIONAL	±0.050	±0.020	±0.005
ANGULAR	±5	±2	±0.5

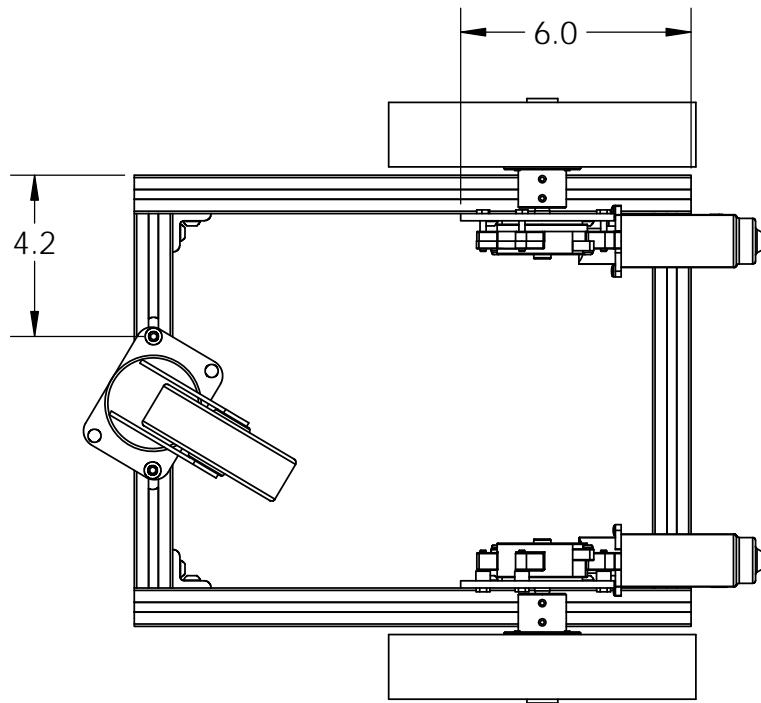
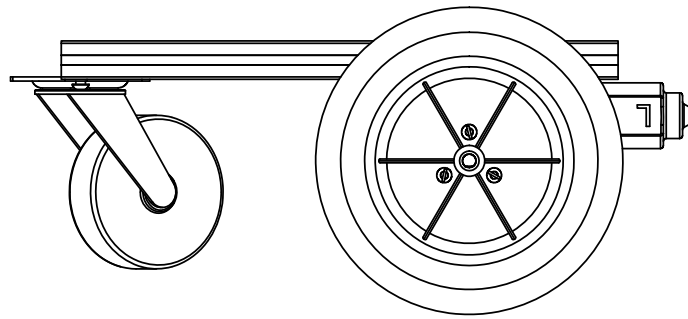

- NOTES:
 1. DIMS IN INCHES
 2. QUANTITY 1

TITLE:				Mobile Platform Assembly		
DRAWN				S. MASCIELLO		
DESIGNED				M. BRADDOCK		
DIMENSION TYPE		PLACES IN DIMENSION		SIZE	DWG. NO.	REV
		0.0	0.00	A	EML2322L-A-MP	A
LOCATIONAL		±0.050	±0.020			
ANGULAR		±5	±2			
				SCALE: 1:5		SHEET 2 OF 3

TOLERANCE UNLESS NOTED			
DIMENSION TYPE	PLACES IN DIMENSION		
		0.0	0.00
LOCATIONAL	±0.050	±0.020	±0.005
ANGULAR	±5	±2	±0.5

ITEM NO.	PART NUMBER	DESCRIPTION	QTY.
1	EML 2322L-A-1	Frame Assembly	1
2	EML2322L-A-2	Left Motor Assembly	1
3	EML2322L-A-3	Right Motor Assembly	1
4	EML2322L-013	Caster Wheel - 5 inch Load Height	1
5	EML2322L-007	1/4-20 x 1/2 inch BHCS	6
6	EML2322L-001	1/4-20 T-Nut	6
7	EML2322L-A-4	Wheel Assembly	2
8	EML2322L-005	10-24 x 1/2 inch Socket Set Screw	4

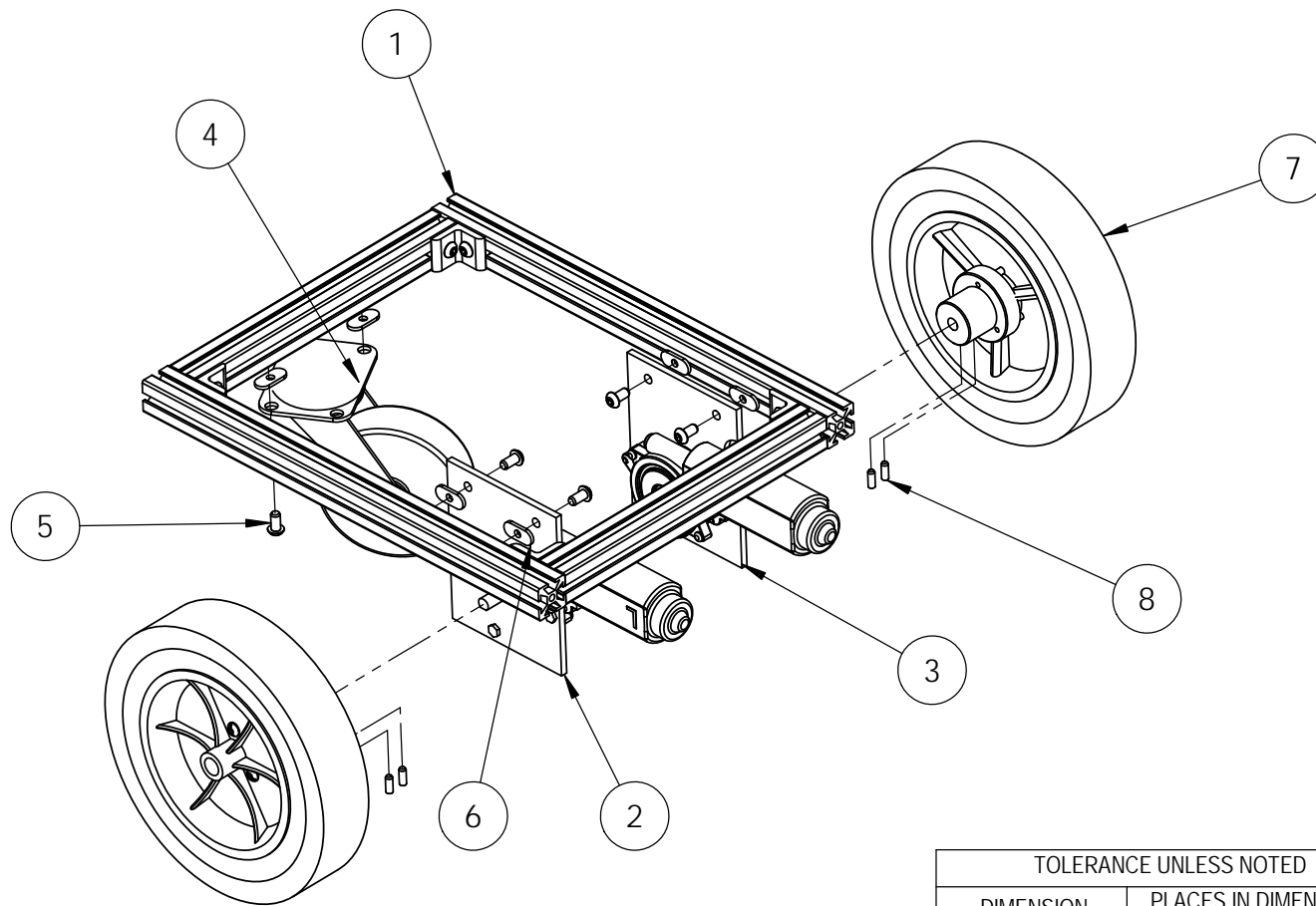

NOTES:
 1. DIMS IN INCHES
 2. QUANTITY 1

TITLE:				Mobile Platform Assembly		
DRAWN				S. MASCIELLO		
DESIGNED				M. BRADDOCK		
DIMENSION TYPE		PLACES IN DIMENSION		SIZE	DWG. NO.	REV
		0.0	0.00	0.000	A	A
LOCATIONAL		±0.050	±0.020	±0.005		
ANGULAR		±5	±2	±0.5		
SCALE: 1:16				SHEET 3 OF 3		

TOLERANCE UNLESS NOTED			
DIMENSION TYPE	PLACES IN DIMENSION		
	0.0	0.00	0.000
LOCATIONAL	±0.050	±0.020	±0.005
ANGULAR	±5	±2	±0.5

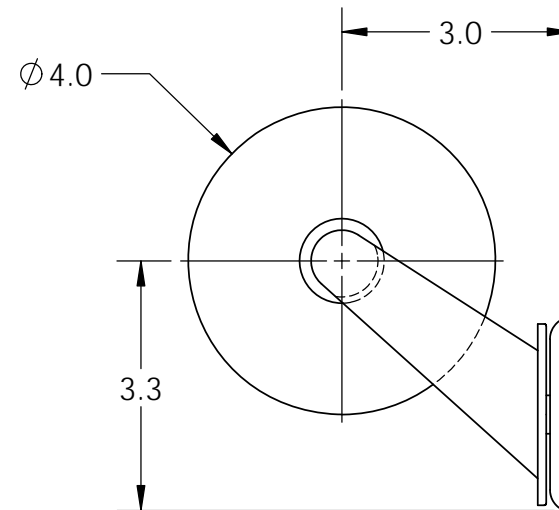
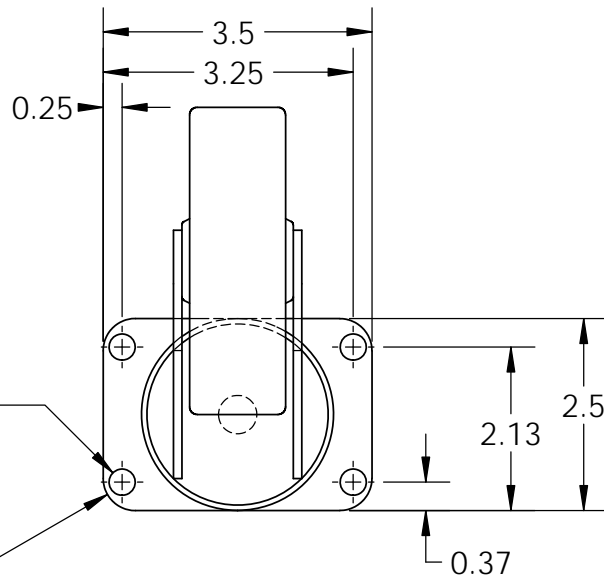
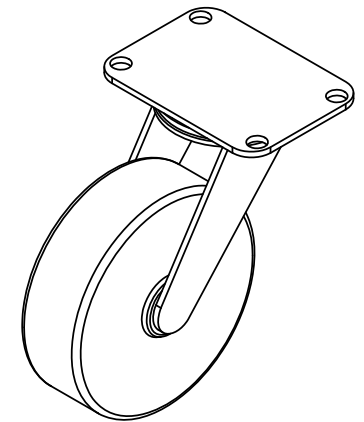
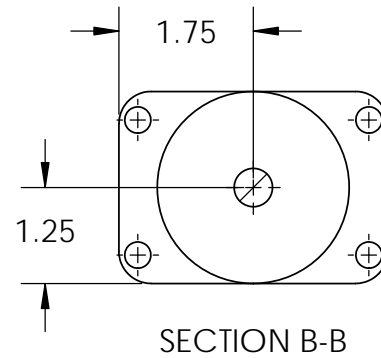
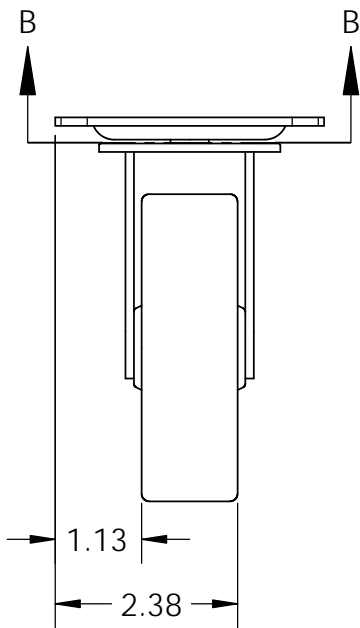

- NOTES:
 1. DIMS IN INCHES
 2. QUANTITY: 1
 3. DIMS AND MAT'L SPECIFIED BY MANUFACTURER

TOLERANCE UNLESS NOTED				TITLE: Caster Wheel		
MEASURING INSTRUMENT	PLACES IN DIMENSION			DRAWN	S. MASCIELLO	
	0.0	0.00	0.000		DESIGNED	ARNOLD
CALIPERS	/	/	±0.005	SIZE	DWG. NO.	REV
PRECISION RULER	/	±0.015	/	A	EML2322L-013	A
TAPE MEASURE	±0.030	/	/	SCALE: 1:2.5	SHEET 1 OF 1	
PROTRACTOR	±10	±5	±2			

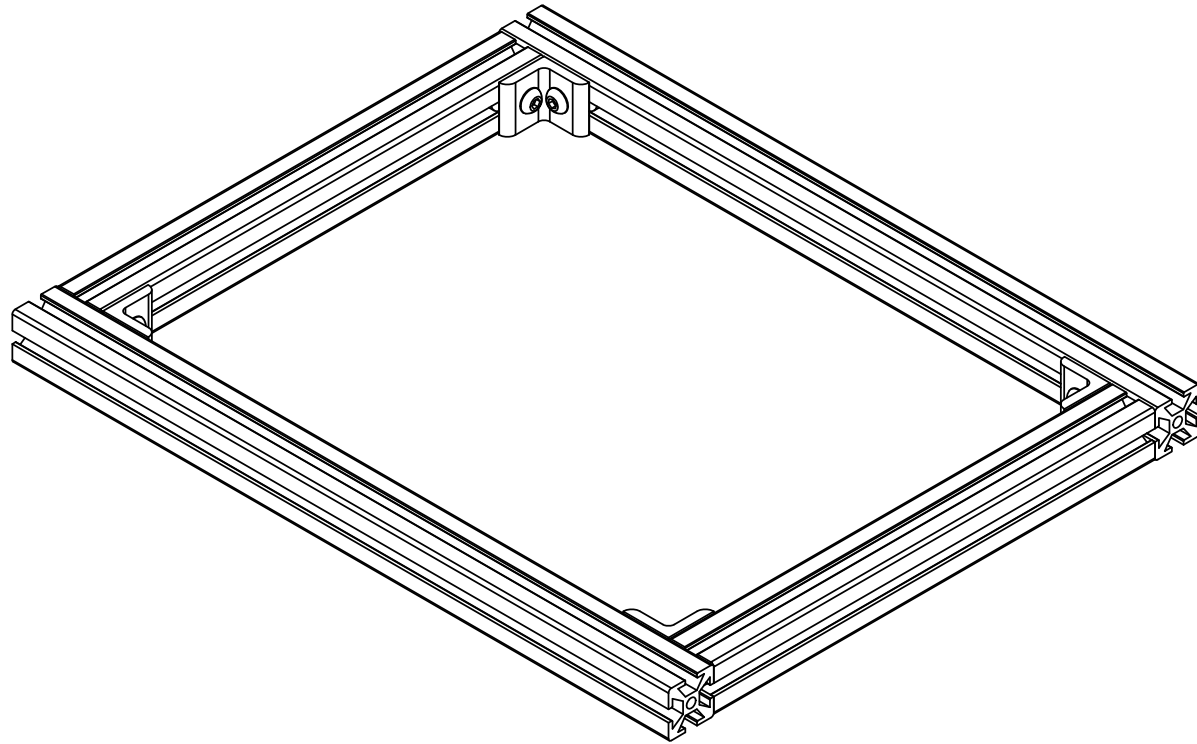

- NOTES:
 1. DIMS IN INCHES
 2. QUANTITY 1

TITLE:		Frame Assembly	
DRAWN		S. MASCIELLO	
DESIGNED		M. BRADDOCK	
SIZE	DWG. NO.	REV	
A	EML2322L-A-1	A	
SCALE: 1:3		SHEET 1 OF 2	

DIMENSION TYPE	TOLERANCE UNLESS NOTED		
	PLACES IN DIMENSION		
	0.0	0.00	0.000
LOCATIONAL	±0.050	±0.020	±0.005
ANGULAR	±5	±2	±0.5

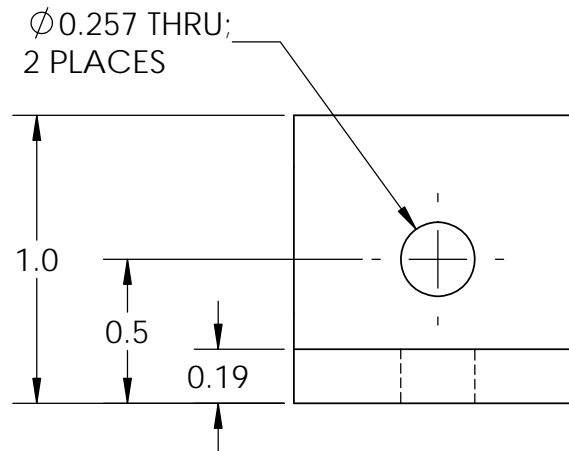
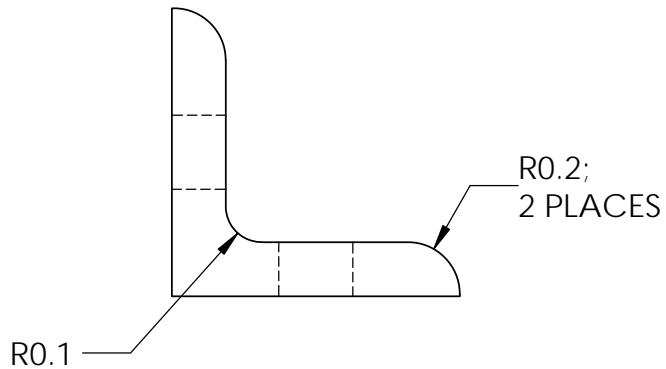
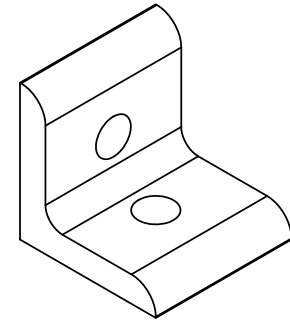
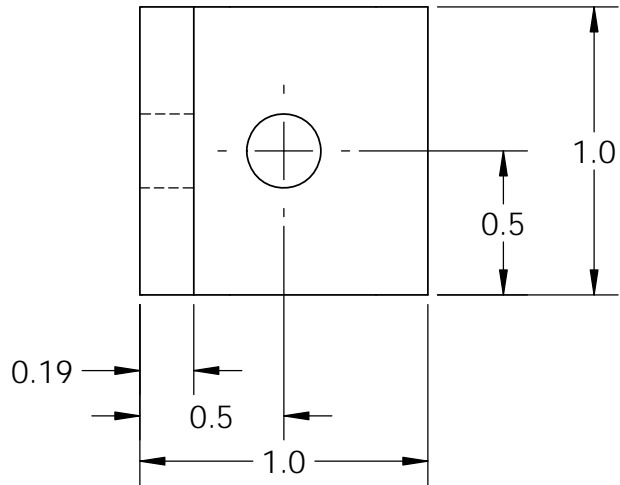

- NOTES:
1. DIMS IN INCHES
 2. QTY SPECIFIED IN BOM
 3. DIMS SPECIFIED BY MANUFACTURER
 4. MAT'L: ALUMINUM

TOLERANCE UNLESS NOTED				TITLE:		
MEASURING INSTRUMENT	PLACES IN DIMENSION			80/20 90 Degree Angle Bracket		
	0.0	0.00	0.000	DRAWN	J. Dersch	
CALIPERS	/	/	±0.005	DESIGNED	80/20 INC.	
PRECISION RULER	/	±0.015	/	SIZE	DWG. NO.	REV
TAPE MEASURE	±0.030	/	/	A	EML2322L-010	A
PROTRACTOR	±10	±5	±2	SCALE: 1.5:1		SHEET 1 OF 1

ITEM NO.	PART NUMBER	DESCRIPTION	QTY.
12	EML2322L-008	150 RPM Denso Right Angle Gearmotor (Left)	1
13	EML2322L-003	Denso Motor Mount	1
14	EML2322L-004	M4x0.7x25mm Hex Head Cap Screw	3
15	EML2322L-021	Denso Motor Mount Spacer	3

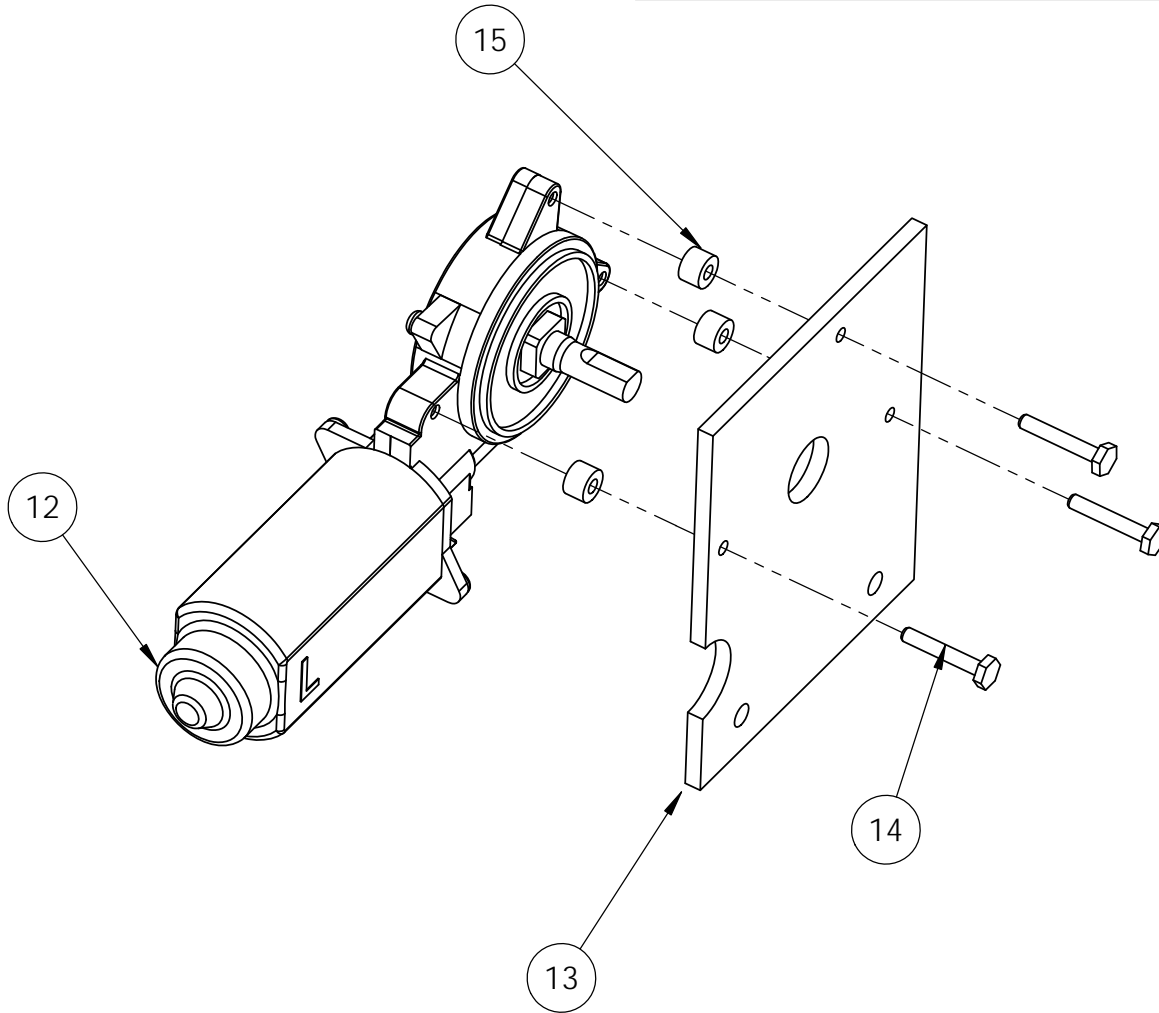

NOTES:
 1. DIMS IN INCHES
 2. QUANTITY 1

TITLE:				Left Motor Assembly		
DRAWN				S. MASCIELLO		
DESIGNED				M. BRADDOCK		
DIMENSION TYPE		PLACES IN DIMENSION		SIZE	DWG. NO.	REV
		0.0	0.00	0.000	A	A
LOCATIONAL		±0.050	±0.020	±0.005		
ANGULAR		±5	±2	±0.5		
SCALE: 1:2				SHEET 2 OF 2		

TOLERANCE UNLESS NOTED			
DIMENSION TYPE	0.0	0.00	0.000
LOCATIONAL	±0.050	±0.020	±0.005
ANGULAR	±5	±2	±0.5

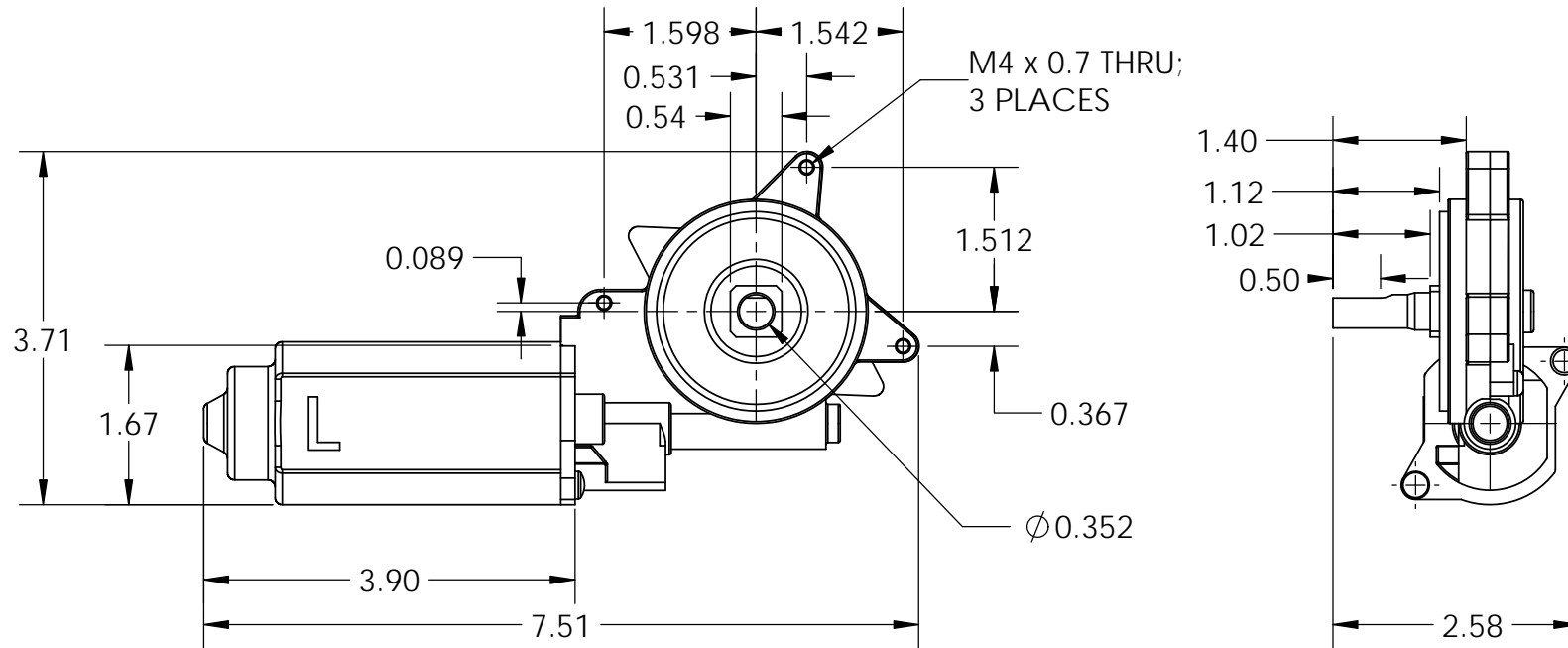
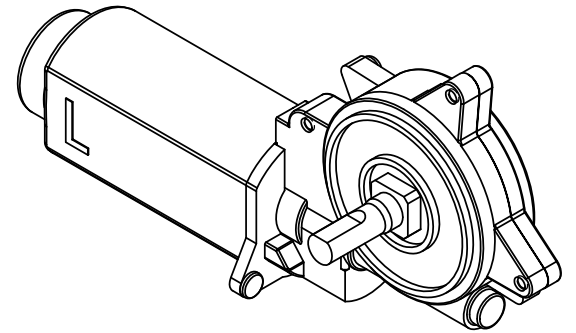

NOTES:

1. DIMS IN INCHES
2. QTY SPECIFIED IN BOM
3. DIMS AND MAT'L SPECIFIED BY MANUFACTURER
4. THE SQUARE EXTRUSION AT THE BASE OF THE SHAFT ROTATES WITH THE SHAFT; USE A 3/4" CLEARANCE HOLE TO ACCOMMODATE THE SQUARE

TOLERANCE UNLESS NOTED				TITLE:		
MEASURING INSTRUMENT	PLACES IN DIMENSION			Denso Right Angle Gear Motor (Left)		
	0.0	0.00	0.000	DRAWN	J. Dersch	
CALIPERS	/	/	± 0.005	DESIGNED	DENSO	
PRECISION RULER	/	± 0.015	/	SIZE	DWG. NO.	REV
TAPE MEASURE	± 0.030	/	/	A	EML2322L-008	A
PROTRACTOR	± 10	± 5	± 2	SCALE: 1:2		SHEET 1 OF 1

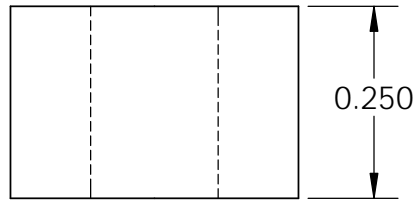
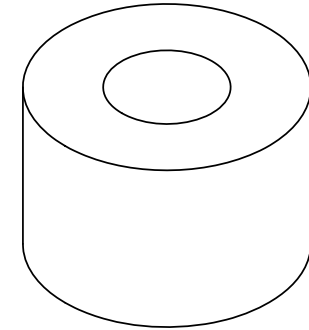
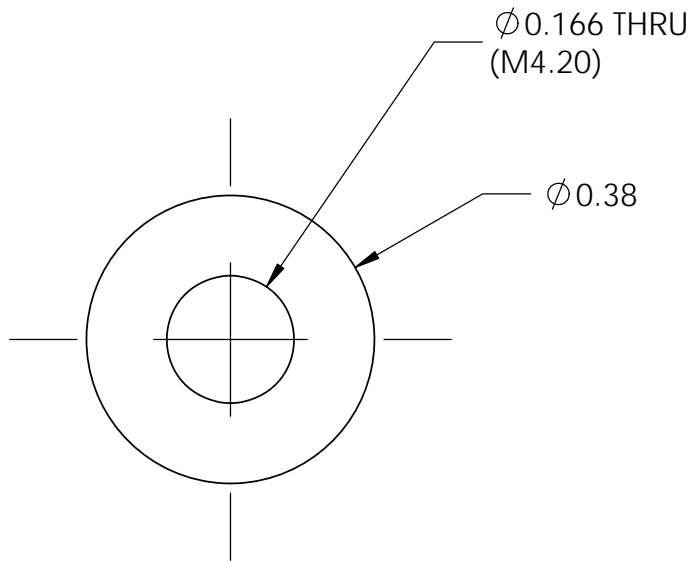

- NOTES:
 1. DIMS IN INCHES
 2. QTY SPECIFIED IN BOM
 3. MAT'L: DELRIN

TOLERANCE UNLESS NOTED				TITLE:		
MEASURING INSTRUMENT	PLACES IN DIMENSION			Denso Motor Mount Spacer		
	0.0	0.00	0.000	DRAWN	S. MASCIELLO	
CALIPERS	/	/	±0.005	DESIGNED	M. BRADDOCK	
PRECISION RULER	/	±0.015	/	SIZE	DWG. NO.	REV
TAPE MEASURE	±0.030	/	/	A	EML2322L-021	A
PROTRACTOR	±10	±5	±2	SCALE: 4:1		SHEET 1 OF 1

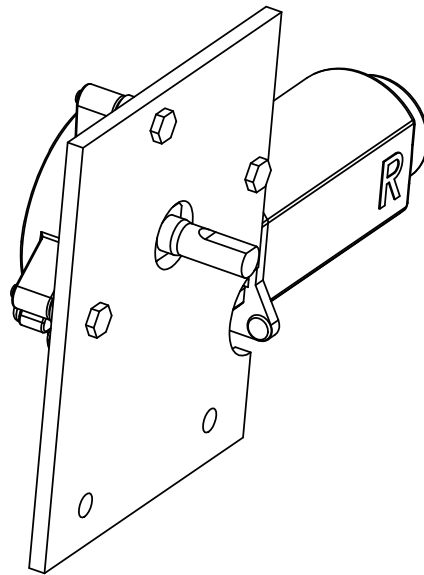

- NOTES:
 1. DIMS IN INCHES
 2. QUANTITY 1

TITLE:		Right Motor Assembly	
DRAWN		S.MASCIELLO	
DESIGNED		M. BRADDOCK	
SIZE	DWG. NO.	REV	
A	EML2322L-A-3	A	
SCALE: 1:2		SHEET 1 OF 2	

DIMENSION TYPE	PLACES IN DIMENSION		
	0.0	0.00	0.000
LOCATIONAL	±0.050	±0.020	±0.005
ANGULAR	±5	±2	±0.5

ITEM NO.	PART NUMBER	DESCRIPTION	QTY.
13	EML2322L-003	Denso Motor Mount	1
14	EML2322L-004	M4x0.7x25mm Hex Head Cap Screw	3
15	EML2322L-021	Denso Motor Mount Spacer	3
16	EML2322L-014	150 RPM Denso Right Angle Gearmotor (Right)	1

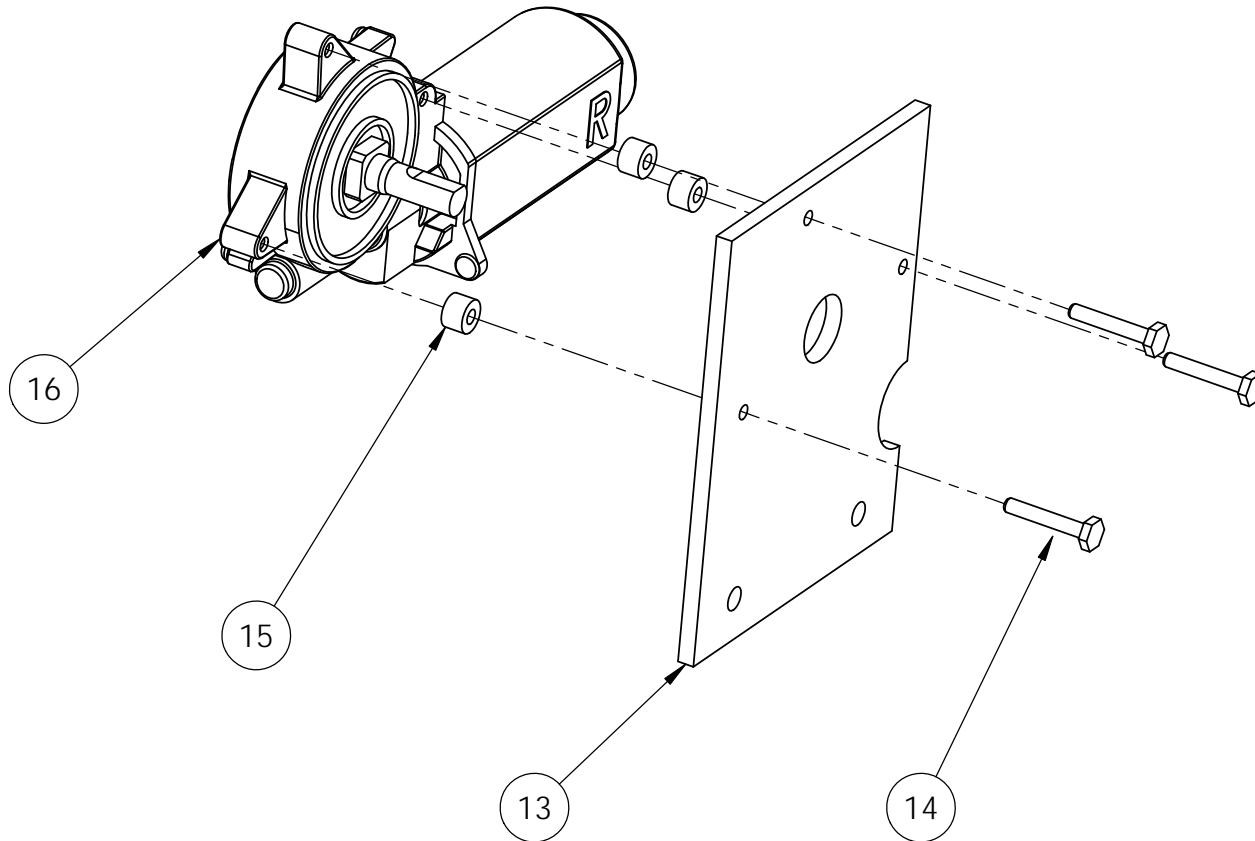

NOTES:
 1. DIMS IN INCHES
 2. QUANTITY 1

TITLE:				Right Motor Assembly		
DRAWN				S.MASCIELLO		
DESIGNED				M. BRADDOCK		
DIMENSION TYPE		PLACES IN DIMENSION		SIZE	DWG. NO.	REV
		0.0	0.00	0.000	A	EML2322L-A-3
LOCATIONAL		±0.050	±0.020	±0.005		
ANGULAR		±5	±2	±0.5		
SCALE: 1:2				SHEET 2 OF 2		

TOLERANCE UNLESS NOTED			
DIMENSION TYPE	PLACES IN DIMENSION		
	0.0	0.00	0.000
LOCATIONAL	±0.050	±0.020	±0.005
ANGULAR	±5	±2	±0.5

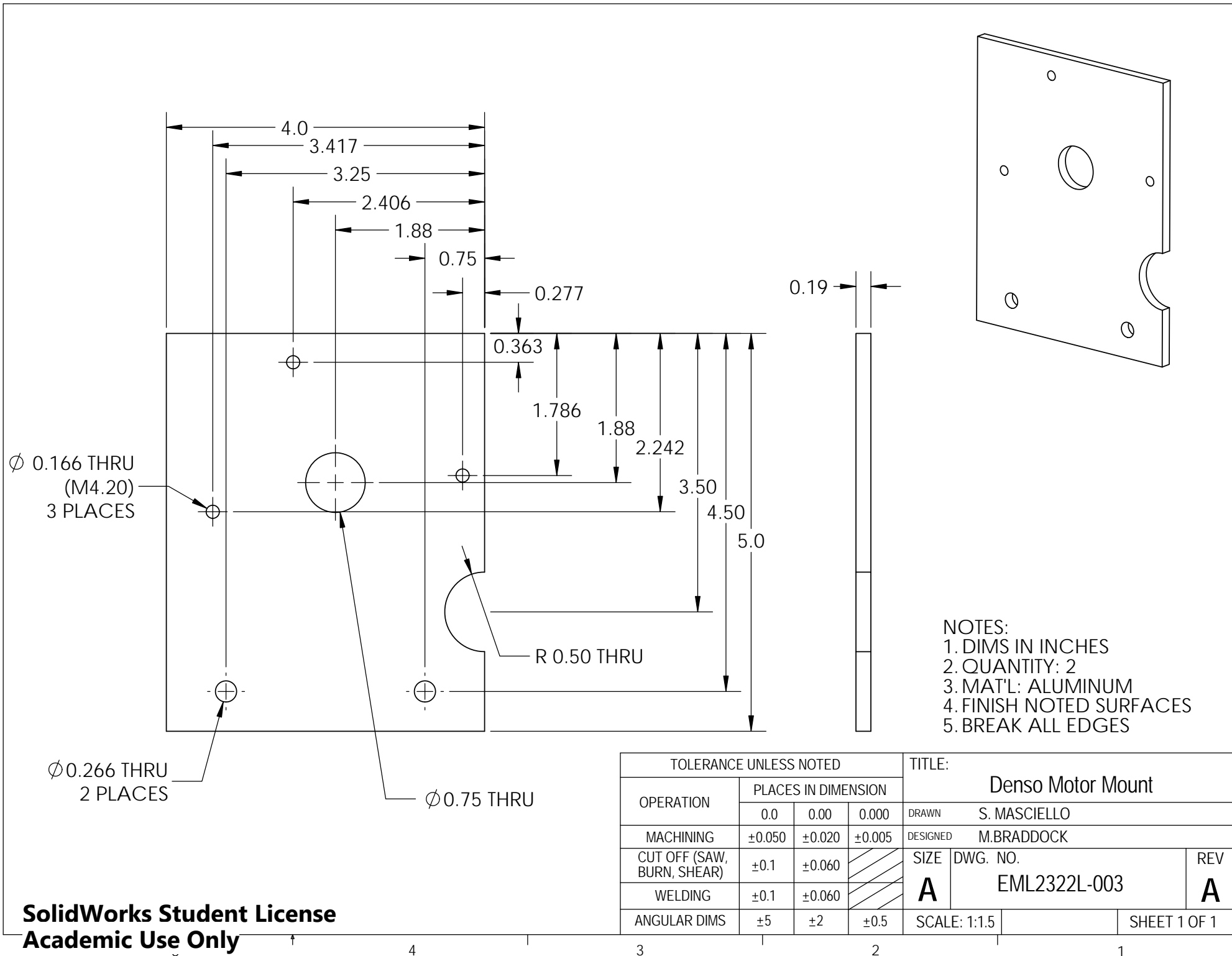

- NOTES:
 1. DIMS IN INCHES
 2. QUANTITY: 2
 3. MAT'L: ALUMINUM
 4. FINISH NOTED SURFACES
 5. BREAK ALL EDGES

TOLERANCE UNLESS NOTED			TITLE:		
OPERATION	PLACES IN DIMENSION			Denso Motor Mount	
	0.0	0.00	0.000	DRAWN	S. MASCIELLO
MACHINING	±0.050	±0.020	±0.005	DESIGNED	M.BRADDOCK
CUT OFF (SAW, BURN, SHEAR)	±0.1	±0.060		SIZE	DWG. NO.
WELDING	±0.1	±0.060		A	EML2322L-003
ANGULAR DIMS	±5	±2	±0.5	SCALE: 1:1.5	SHEET 1 OF 1

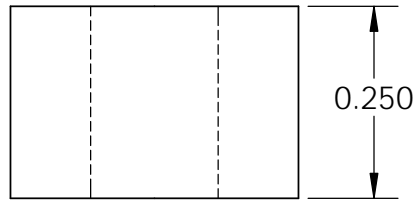
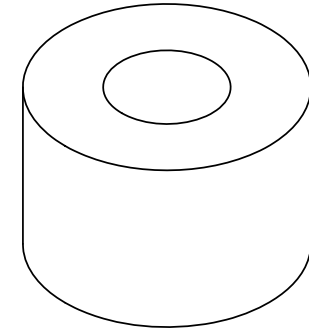
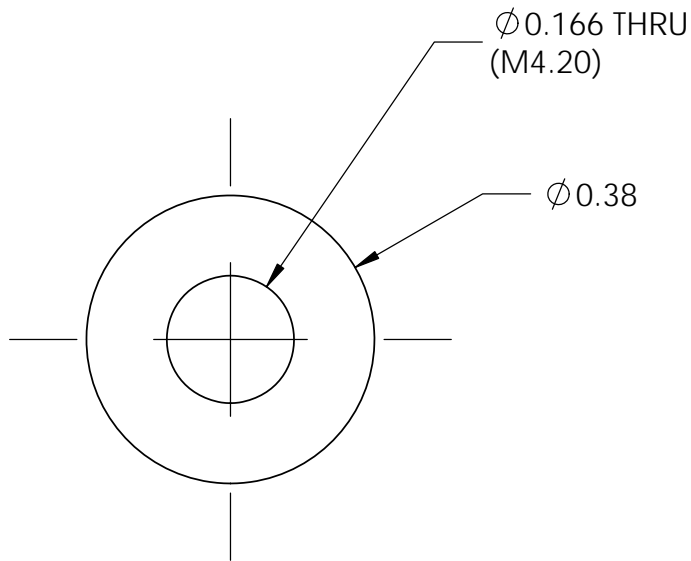

- NOTES:
 1. DIMS IN INCHES
 2. QTY SPECIFIED IN BOM
 3. MAT'L: DELRIN

TOLERANCE UNLESS NOTED				TITLE:		
MEASURING INSTRUMENT	PLACES IN DIMENSION			Denso Motor Mount Spacer		
	0.0	0.00	0.000	DRAWN	S. MASCIELLO	
CALIPERS	/	/	±0.005	DESIGNED	M. BRADDOCK	
PRECISION RULER	/	±0.015	/	SIZE	DWG. NO.	REV
TAPE MEASURE	±0.030	/	/	A	EML2322L-021	A
PROTRACTOR	±10	±5	±2	SCALE: 4:1		SHEET 1 OF 1

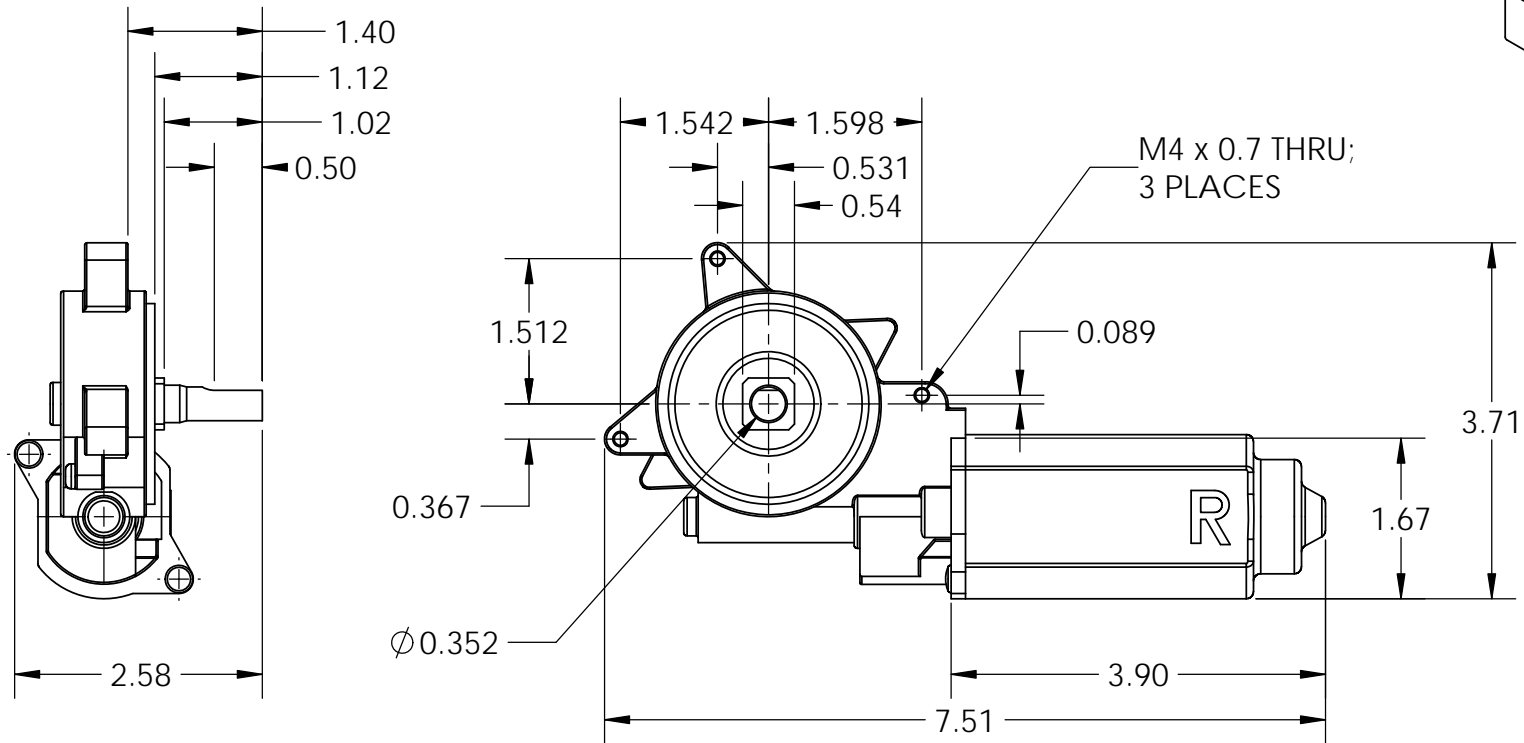
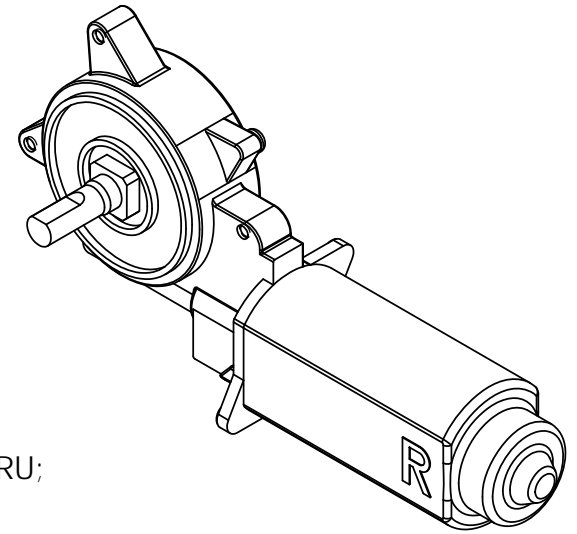

NOTES:

1. DIMS IN INCHES
2. QTY SPECIFIED IN BOM
3. DIMS AND MAT'L SPECIFIED BY MANUFACTURER
4. THE SQUARE EXTRUSION AT THE BASE OF THE SHAFT ROTATES WITH THE SHAFT; USE A 3/4" CLEARANCE HOLE TO ACCOMMODATE THE SQUARE

TOLERANCE UNLESS NOTED				TITLE:		
MEASURING INSTRUMENT	PLACES IN DIMENSION			Denso Right Angle Gear Motor (Right)		
	0.0	0.00	0.000	DRAWN	J. DERSCH	
CALIPERS	/	/	±0.005	DESIGNED	DENSO	
PRECISION RULER	/	±0.015	/	SIZE	DWG. NO.	REV
TAPE MEASURE	±0.030	/	/	A	EML2322L-014	A
PROTRACTOR	±10	±5	±2	SCALE: 1:2		SHEET 1 OF 1

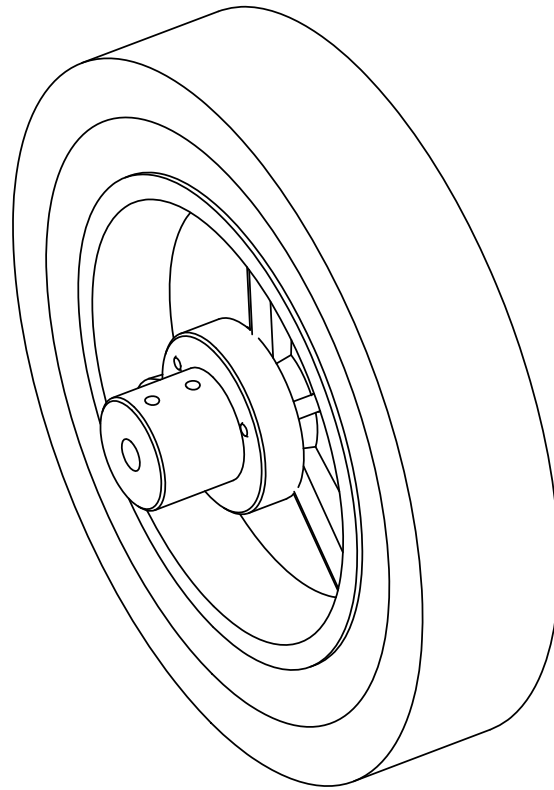

- NOTES:
 1. DIMS IN INCHES
 2. QUANTITY 2

TITLE:		Wheel Assembly	
DRAWN	J. Dersch		
DESIGNED	M. BRADDOCK		
SIZE	DWG. NO.	REV	
A	EML2322L-A-4	A	
SCALE: 1:2		SHEET 1 OF 2	

DIMENSION TYPE	PLACES IN DIMENSION		
	0.0	0.00	0.000
LOCATIONAL	±0.050	±0.020	±0.005
ANGULAR	±5	±2	±0.5

ITEM NO.	PART NUMBER	DESCRIPTION	QTY.
17	EML2322L-011	8 inch Wheel Type 1	1
18	EML2322L-002	Denso Wheel Hub	1
19	EML2322L-006	10-24 x 1 inch Round Head Screw	3

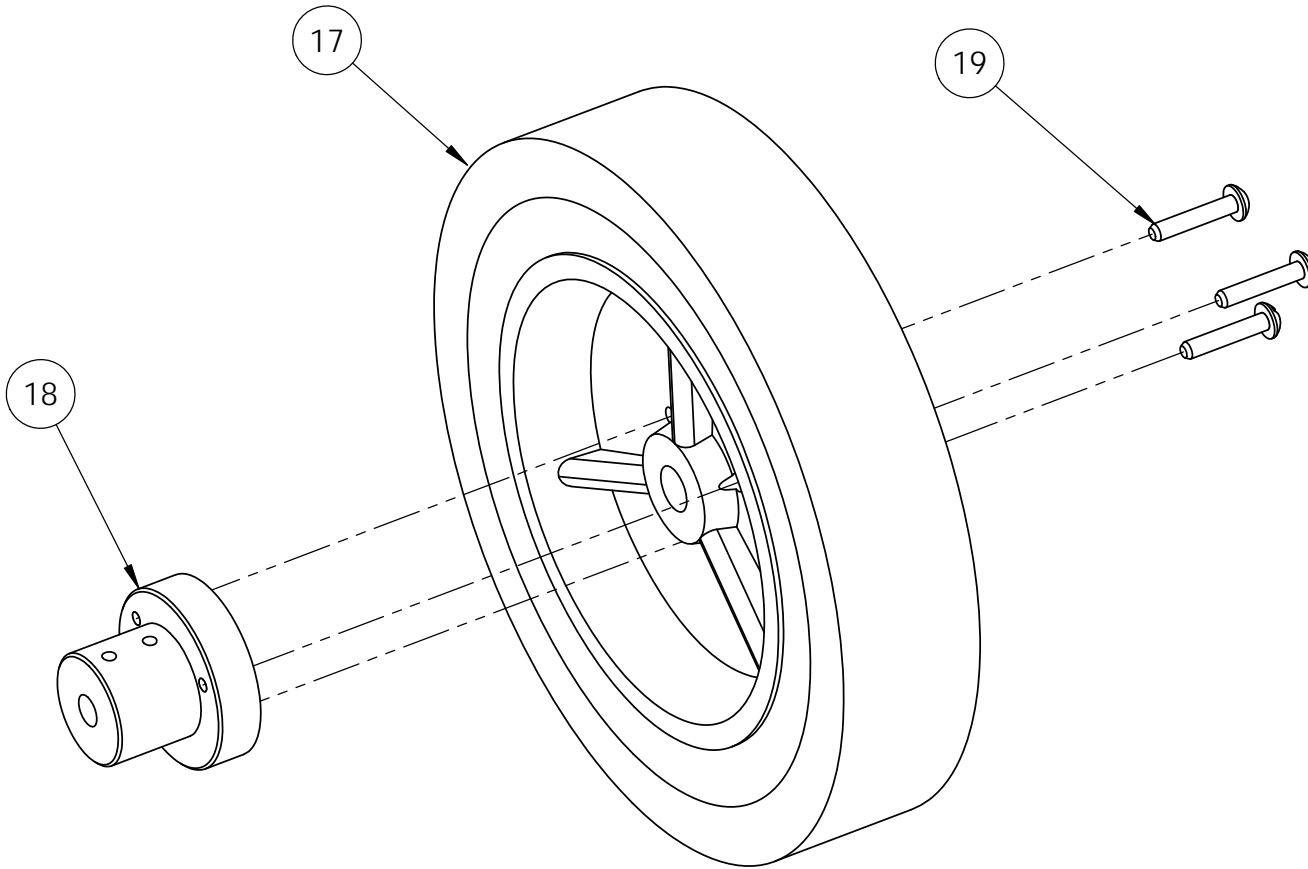

NOTES:
 1. DIMS IN INCHES
 2. QUANTITY 2

TITLE:				Wheel Assembly		
DRAWN				J. Dersch		
DESIGNED				M. BRADDOCK		
DIMENSION TYPE		PLACES IN DIMENSION		SIZE	DWG. NO.	REV
		0.0	0.00	A	EML2322L-A-4	A
LOCATIONAL		±0.050	±0.020			
ANGULAR		±5	±2	SCALE: 1:2		SHEET 2 OF 2

TOLERANCE UNLESS NOTED			
	0.0	0.00	0.000
LOCATIONAL	±0.050	±0.020	±0.005
ANGULAR	±5	±2	±0.5

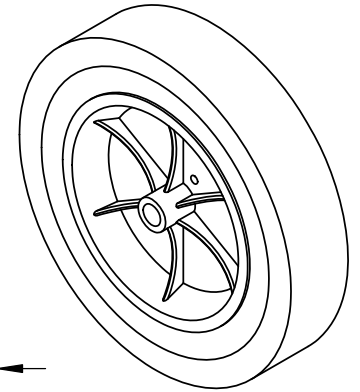
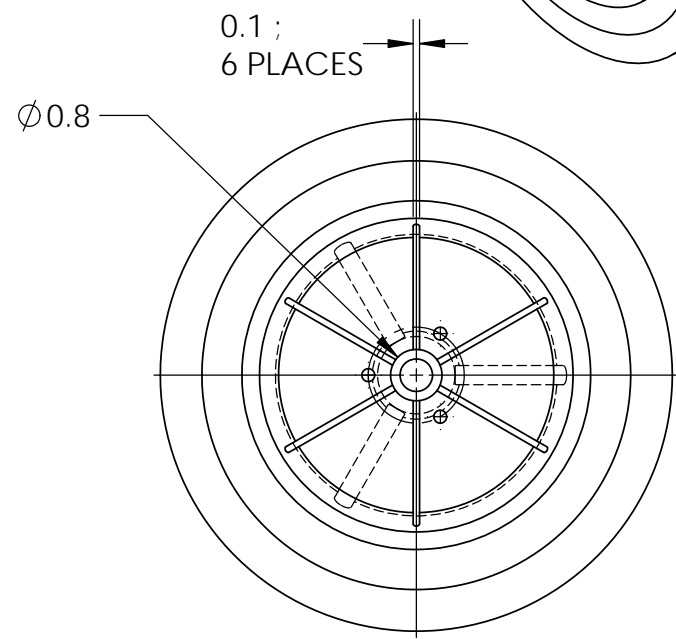
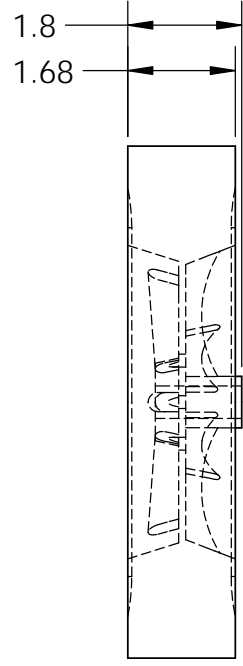
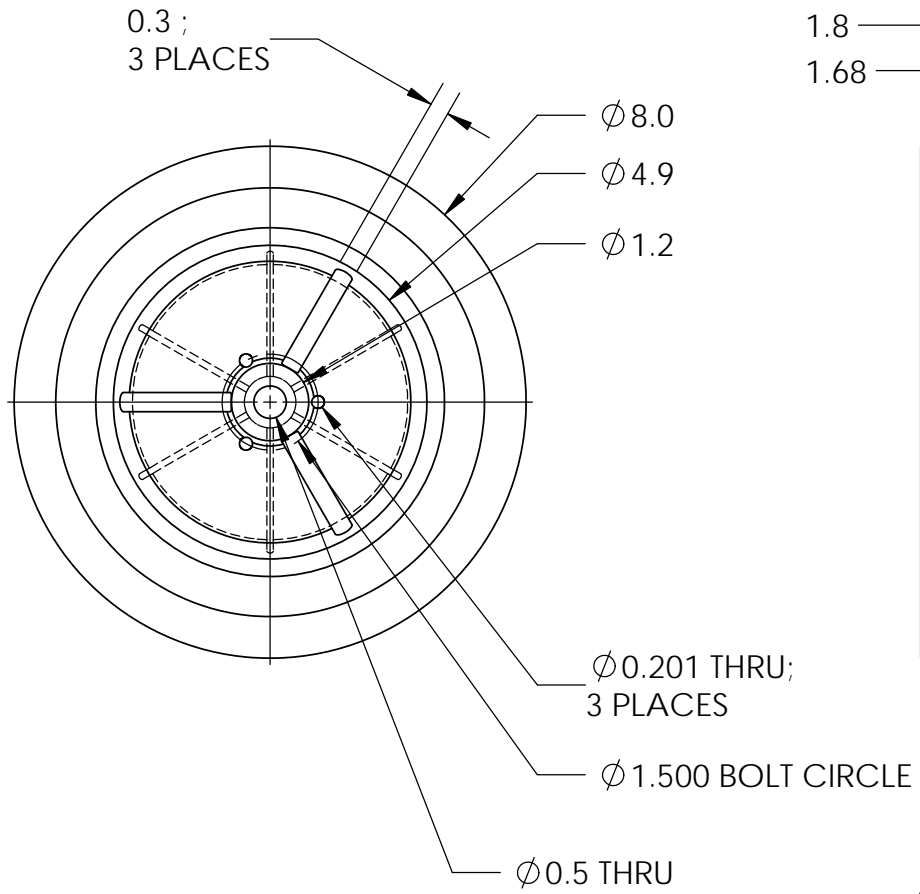

- NOTES:
 1. DIMS IN INCHES
 2. QTY SPECIFIED IN BOM
 3. DIMS AND MAT'L SPECIFIED BY MANUFACTURER

SolidWorks Student License
Academic Use Only

TOLERANCE UNLESS NOTED				TITLE:		
MEASURING INSTRUMENT	PLACES IN DIMENSION			8 Inch Wheel Type 1		
	0.0	0.00	0.000	DRAWN	J. Dersch	
CALIPERS	/	/	±0.005	DESIGNED	ARNOLD	
PRECISION RULER	/	±0.015	/	SIZE	DWG. NO.	REV
TAPE MEASURE	±0.030	/	/	A	EML2322L-011	A
PROTRACTOR	±10	±5	±2	SCALE: 1:3		SHEET 1 OF 2

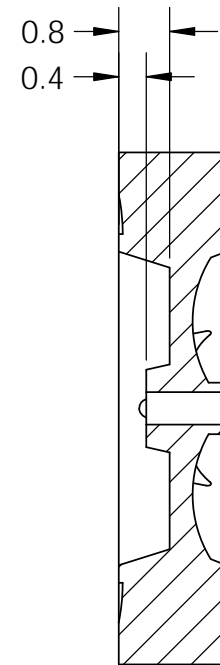
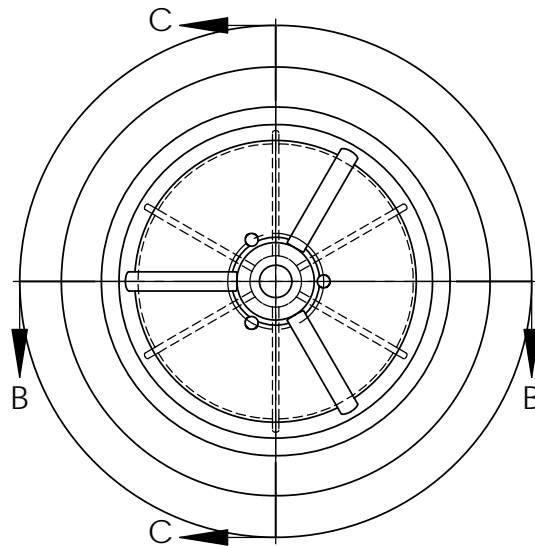
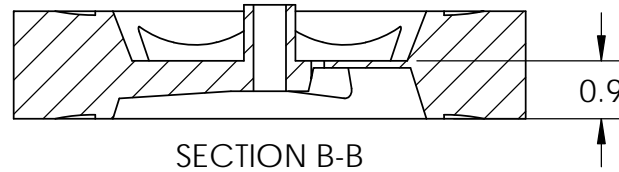

SECTION C-C

NOTES:

1. DIMS IN INCHES
2. QTY SPECIFIED IN BOM
3. DIMS AND MAT'L SPECIFIED BY MANUFACTURER

SolidWorks Student License
Academic Use Only

TOLERANCE UNLESS NOTED				TITLE:		
MEASURING INSTRUMENT	PLACES IN DIMENSION			8 Inch Wheel Type 1		
	0.0	0.00	0.000	DRAWN	J. Dersch	
CALIPERS	/	/	±0.005	DESIGNED	ARNOLD	
PRECISION RULER	/	±0.015	/	SIZE	DWG. NO.	REV
TAPE MEASURE	±0.030	/	/	A	EML2322L-011	A
PROTRACTOR	±10	±5	±2	SCALE: 1:3		SHEET 2 OF 2

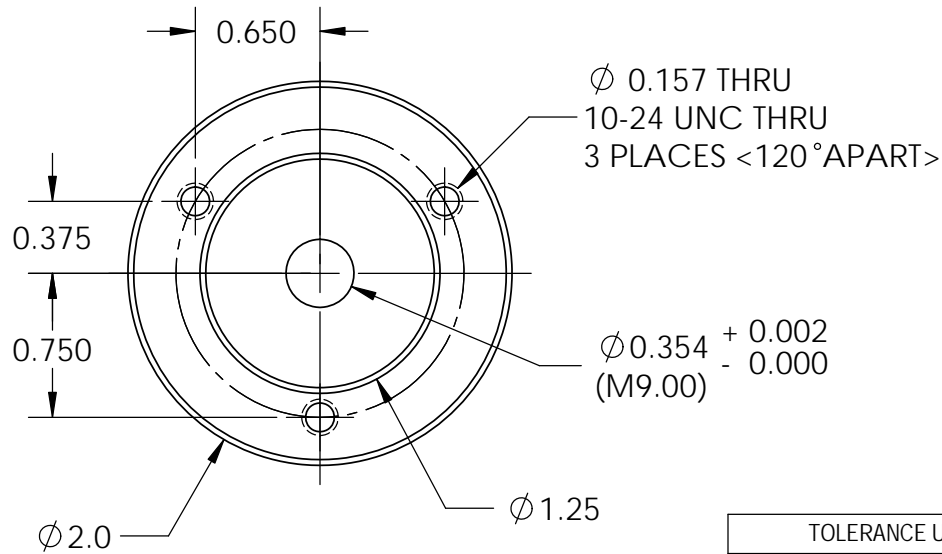
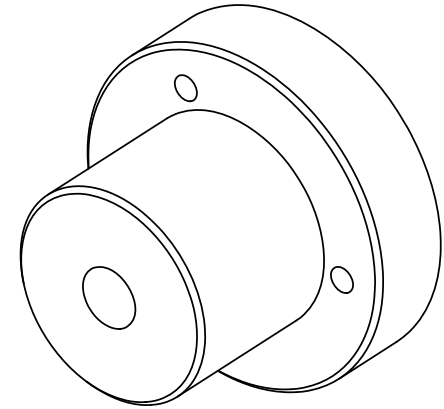
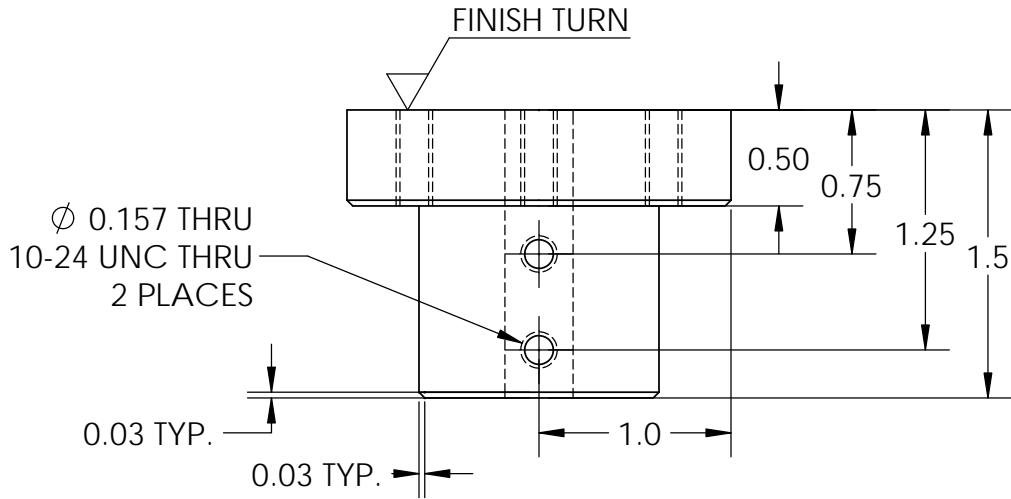

- NOTES:
1. DIMS IN INCHES
 2. QUANTITY: 2
 3. MAT'L: ALUMINUM
 4. FINISH NOTED SURFACES
 5. BREAK ALL EDGES

TOLERANCE UNLESS NOTED			TITLE:		
OPERATION	PLACES IN DIMENSION			Denso Wheel Hub	
	0.0	0.00	0.000	DRAWN	S. MASCIELLO
MACHINING	±0.050	±0.020	±0.005	DESIGNED	M. BRADDOCK
CUT OFF (SAW, BURN, SHEAR)	±0.1	±0.060		SIZE	DWG. NO.
WELDING	±0.1	±0.060		A	EML2322L-002
ANGULAR DIMS	±5	±2	±0.5	SCALE: 1:1	SHEET 1 OF 1
					REV
					A