

200 RPM SYL Gearmotor

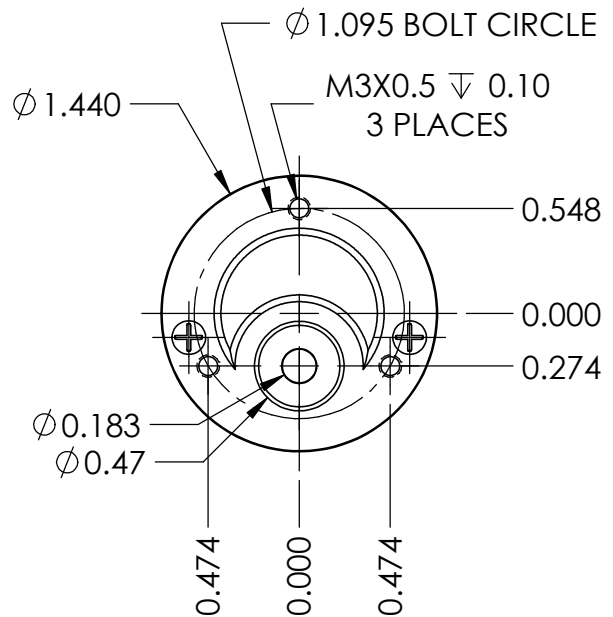
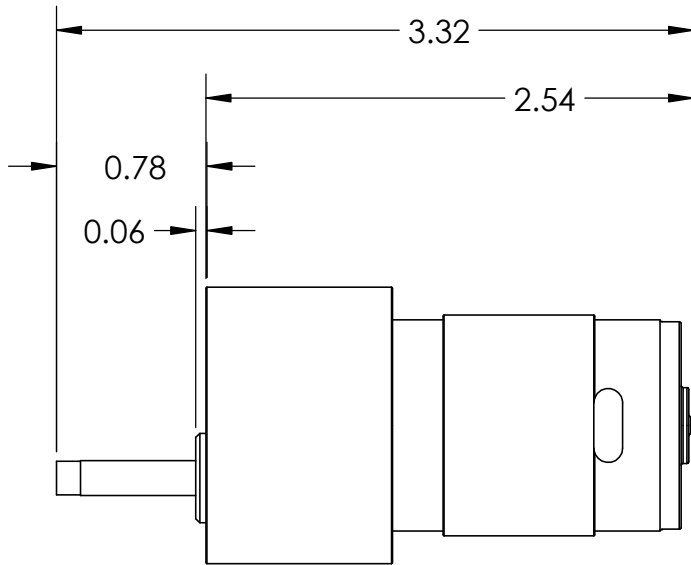
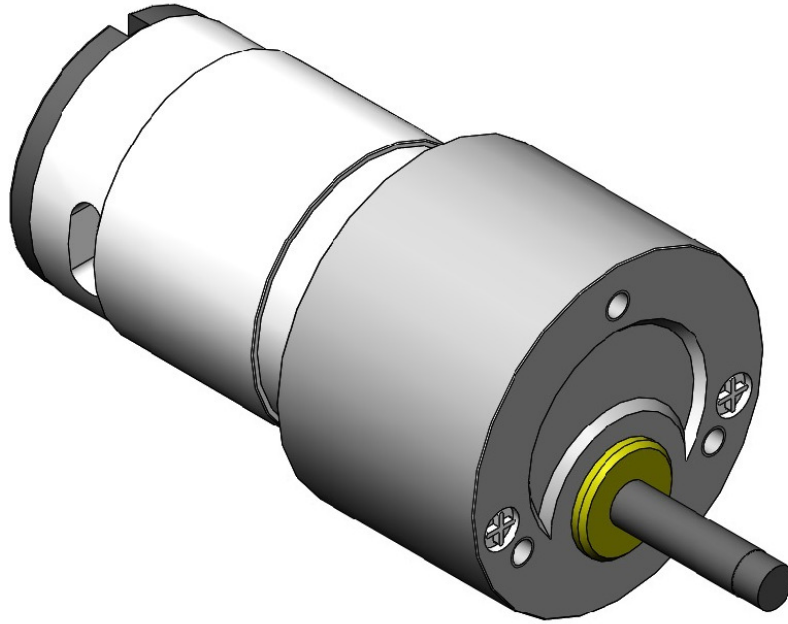

Specifications:

Voltage: 12 VDC

Current: 60mA (no load)

Speed: 200 RPM (no load)

Torque: 25 in-oz

Back-drive Torque: 20 in-oz (estimated)

Reversible

Weight: 0.4 lb