

Lifting Motor Torque Calculations

To calculate the torque required to operate a gate or lifting mechanism, the centroid (or center of mass) and weight of each component must be accounted for. The following example presents one method of computing this torque.

Example lifting arm design criteria:

- 80/20 length ($L_{80/20}$): 10 in
- Sheetmetal thickness (t_s): 16 GA
- Sheetmetal area (A_s): 5 in x 4 in
- Linear mass density of 80/20 ($\lambda_{80/20}$): 0.510 lb/ft
- Density of steel (ρ_{steel}): 0.284 lb/in³

Step One: Determine Component Weights

Weight can always be determined from a material's density and volume, but for components with complex cross sectional areas (such as 80/20), using the material's linear mass density (i.e. weight per unit length) can simplify the calculation.

For 80/20:

$$W_{80/20} [\text{lb}] = L [\text{ft}] \times \lambda_{80/20} [\text{lb/ft}]$$

where:

$$W_{80/20} = \text{weight of 80/20 [lb]}$$

$$L_{80/20} = \text{length of 80/20 [ft]}$$

$$\lambda_{80/20} = \text{weight per foot of 80/20 [lb/ft]}$$

Example:

$$W_{80/20} [\text{lb}] = 10 \text{ in} \times (1 \text{ ft} / 12 \text{ in}) \times 0.510 \text{ lb/ft} = \underline{0.43 \text{ lb}}$$

For sheetmetal:

$$W_s [\text{lb}] = A_s [\text{in}^2] \times t_s [\text{in}] \times \rho_{steel} [\text{lb/in}^3]$$

where:

$$W_s = \text{weight of sheetmetal [lb]}$$

$$A_s = \text{area of sheetmetal [in}^2\text{]}$$

$$t_s = \text{thickness of sheetmetal [in]}$$

$$\rho_{steel} = \text{density of steel [lb/in}^3\text{]}$$

Example:

$$W_s = (5 \text{ in} \times 4 \text{ in}) \times 0.060 \text{ in} \times 0.284 \text{ lb/in}^3 = \underline{0.34 \text{ lb}}$$

Table 1: Sheetmetal Gage Thicknesses

Sheet Gage	Steel [in]	Aluminum [in]
16 GA	0.060	0.051
18 GA	0.048	0.040
20 GA	0.036	0.032

Step Two: Calculate Center of Mass

The center of mass and centroid of an object are similar but the center of mass applies when you have components of different materials. Use symmetry to find individual centroids, X_c , but remember the distances should be measured from the rotating axis.

$$X_{com} [\text{in}] = \frac{\sum(X_c [\text{in}] \times W [\text{lb}])}{\sum(W [\text{lb}])}$$

Where:

$$X_{com} = \text{center of mass in x-direction [in]}$$

$$X_c = \text{centroid of each component [in]}$$

$$W = \text{weight of each component [lb]}$$

Example:

Please see the illustration on the next page.

$$X_{com} = (3.51 \text{ in} \times 0.43 \text{ lb} + 8.54 \text{ in} \times 0.34 \text{ lb}) / (0.43 \text{ lb} + 0.34 \text{ lb}) = \underline{5.73 \text{ in}}$$

Step Three: Calculate Gate / Lifting Arm Torque

$$T_{gate/arm} [\text{lb-in}] = X_{com} [\text{in}] \times W_{total} [\text{lb}]$$

Where:

$$T_{gate/arm} = \text{required torque to operate gate/arm [lb-in]}$$

$$X_{com} = \text{center of mass in x-direction [in]}$$

$$W_{total} = \text{total weight [lb]}$$

Example:

$$T_{gate/arm} = 5.73 \text{ in} \times (0.43 \text{ lb} + 0.34 \text{ lb}) = \underline{4.41 \text{ lb-in}}$$

Note: For more complex geometries the total weight and center of mass can be found using SolidWorks. To do this, all material densities must be specified correctly.

Source for linear mass density of 80/20:

<http://www.8020.net>

Lifting Motor Torque Calculations

Step Four: Calculate Required Motor Torque

The final step is to verify the selected motor can produce the required torque. To account for the acceleration of the moving components and typical manufacturing and assembly tolerances in brushed-type electric motors, use an efficiency factor of approximately 60%.

$$T_{M, REQ'D} = T_{gate/arm} [lb-in] / \eta$$

where:

$T_{M, REQ'D} [lb-in]$ = required motor torque [lb-in]

$T_{gate/arm} [lb-in]$ = required gate/arm torque [lb-in]

η [%] = efficiency factor \approx 60%

Example:

$$T_{M, REQ'D} = 4.41 \text{ lb-in} / 0.60 = \underline{7.4 \text{ lb-in}}$$

Interpreting Results:

This design would require a motor that produces a minimum of 7.4 lb-in of torque to ensure the gate/arm assembly can be properly actuated. If that size motor is unavailable or too large to fit the required space, a number of options exist to remedy the problem:

1. Redesign the mechanism to use a shorter pivot length, reducing the required torque
2. Redesign the mechanism to use materials with lower densities, reducing the required torque
3. Redesign the mechanism to use an assist spring, reducing the required torque

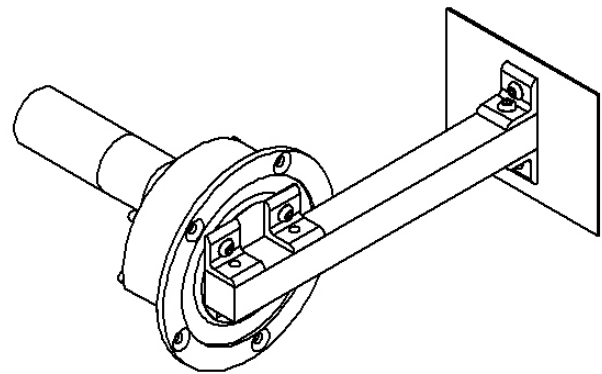
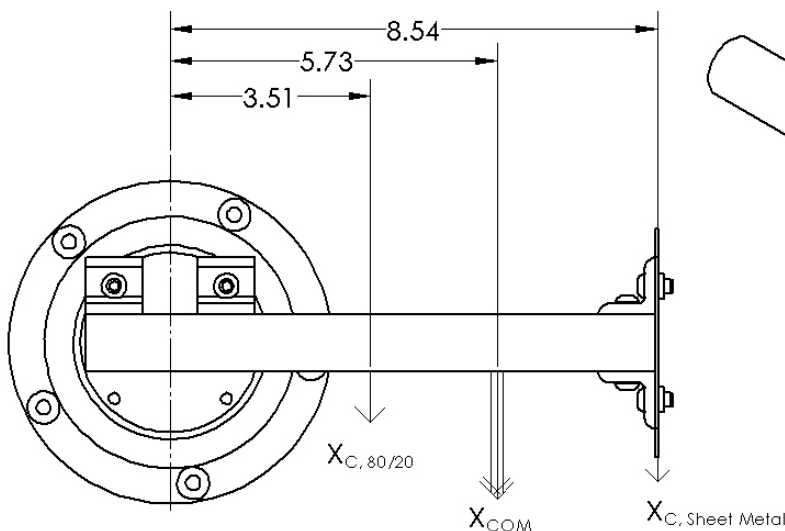

Weights
 80/20 = 0.43 lbs
 Sheet Metal = 0.34 lbs
 Total = 0.77 lbs

$$\begin{aligned} X_{com} &= ((X_{C, 80/20}) \times (W_{80/20}) + (X_{C, Sheet Metal}) \times (W_{Sheet Metal})) / (W_{Total}) \\ &= (3.51 \text{ in} \times 0.43 \text{ lbs} + 8.54 \text{ in} \times 0.34 \text{ lbs}) / 0.77 \text{ lbs} \\ &= 5.73 \text{ in} \end{aligned}$$

$$\begin{aligned} \text{Torque} &= X_{COM} \times (W_{Total}) \\ &= 5.73 \text{ in} \times 0.77 \text{ lbs} = 4.41 \text{ lb-in} \end{aligned}$$

Dimensions in Inches